

Digital Glycol Feeder



Digital Glycol Feeder

Pulsafeeder's Digital Glycol Feeder provides a consistent operating pressure in closed loop systems. This allows a controlled percentage of glycol solution to be fed from the 55 gallon tank. The Digital Glycol Feeder is available in two models; the DGF1 for single loop and the DGF2 for dual loop systems.

The control unit utilizes an 8-bit microcontroller for precise feed system control. The NEMA4X enclosure can be wired conduit or prewire for easy startup. The preplumbed assembly includes a pressure gauge, pressure switch, and pressure relief valve to prevent excessive pressure build up. A low liquid level switch with optional audible alarm prevents the gear pump from operating when the solution is low.

Each Digital Glycol Feeder is fully piped and wired with the following components:

Suction Assembly includes:

PVC tubing and fittings
PVC ball valve
Clear poly bowl strainer

Discharge Assembly Includes:

PVC pipe and fittings
PVC ball valve
PVC check valve
Pressure gauge
Brass relief valve with return to tank tubing

Controller Features

- **Compact NEMA4X enclosure** for industrial applications
- **Touch keypad** user interface for gear pump operation
- **LED indicators** loss of pressure and low level
- **HOA control** of pumps and alarm to force relay OFF indefinitely or force relay ON for a period of 5 minutes
- **Alarm silence** feature
- **Dual alarm relay outputs** are factory configured for dry contact or powered
- **Available in 115V or 230V**
- **Agency approved** for US and Canada



Pump Features

- **Heavy duty gear pump**
- **Bronze and stainless steel wetted components**
- **Close tolerance design** allows for consistent performance
- **Helical gears** for quiet operation

System Features

- **Economical design** for competitive bid specifications



technology
innovation
diversity
excellence

Digital Glycol Feeder

DIGITAL GLYCOL FEEDER Selection Guide		DGF	-	-	-	-	-	-
CLOSED LOOPS Position 4	1 = Single Loop 2 = Dual Loop							
CONDUIT / PREWIRE Position 5	A = Conduit B = Prewire							
AUDIBLE ALARM Position 6	A = without Audible Alarm B = with Audible Alarm							
ALARM OUTPUT OPTION Position 7	X = None A = Dry Contact, Single B = Dry Contact, Dual C = AC Output, Single D = AC Output, Dual E = Dry Contact, Single & AC Output, Single							
PRESSURE SWITCH OPTION Position 8	A = Standard pressure switch, 30 to 50 psi (adjustable to 80 psi) B = Low pressure switch, 5 to 10 psi (adjustable to 35 psi) C = One standard and one low pressure switch (DGF2 only)							
PUMP AND VOLTAGE RATING Position 9	A = 115VAC no pump B = 230VAC no pump (must be conduit) C = 115VAC 60Hz 1.50GPM @ 100psi E = 115VAC 60Hz 3.75GPM @ 100 psi							
AGENCY APPROVAL Position 10	X = None A = ETL Approval							
PANEL ASSEMBLY Position 11	B = Assembled (must ship via freight)							

Dimensions

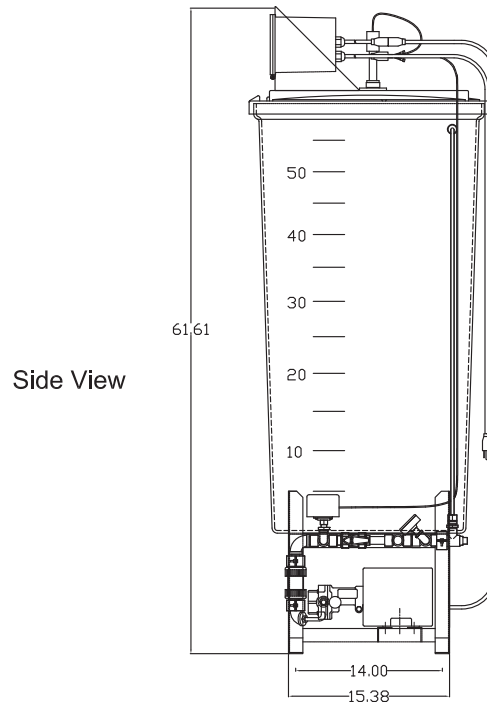
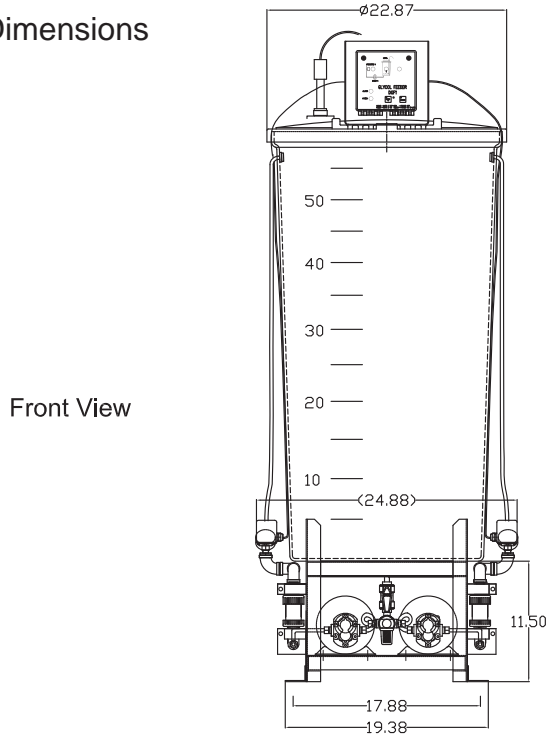

An ISO 9001 and 14001 Certified Company



A Unit of IDEX Corporation

Standard Product Operations

27101 Airport Road • Punta Gorda, Florida 33982
 TEL (941) 575-3800 • TEL 800-333-6677
 FAX (941) 575-4085 • FAX 800-456-4085
 spottech@pulsa.com • www.pulsa.com