

Vision Model UV

PROCESS CONTROL INSTRUMENT

TECHNICAL REFERENCE GUIDE



Patent Pending

Table of Contents

1.0	INTRODUCTION.....	8
1.1	Description	9
2.0	INSTALLATION.....	9
2.1	Location.....	9
2.2	Installation Notes.....	11
2.2.1	Probe Installation (In-Line)	12
2.2.2	Probe Installation (Submersible)	15
2.3	USB Cable to CAT 5 Cable Adapter	16
2.3.0	RJ45 Connector Wiring	17
2.3.1	Boiler Probe Installation	18
2.3.2	Installing the IntelliSense.....	18
2.3.3	Installing Boiler Probe Cable to the IntelliSense Adapter.....	18
2.4	Installing USB/CAT 5E Cables to IntelliSense	19
2.5	Installing USB/CAT 5E Cables to Controller	19
2.6	Accessories	20
2.7	Electrical Wiring.....	20
2.7.1	User Connections	21
2.7.1.1	Open the Enclosure	21
2.7.1.2	Relay Connections	21
2.7.1.3	Flow Switch or Interlock	23
2.7.1.4	Water Meter (for Pulse Timer)	23
2.7.1.5	Hall Effect Water Meter	24
3.0	START UP INSTRUCTIONS	25
3.1	Front Panel.....	26
3.2	Keypad Operation	26
3.3	Menu Structure.....	27
3.3.1	View Alarms	27
3.3.2	View Service	27
3.3.3	Configure Data Set.....	27
3.3.4	Control Model.....	27
3.3.4.1	Cooling Tower	27
3.3.4.2	Boiler	28
3.3.4.3	Process Cntrl.....	29
3.4	Sample Programming.....	29
4.0	SYSTEM SETUP.....	30
4.1	Security	30
4.2	Set Date	31
4.3	Set Time.....	31
4.4	Set Date Format.....	31
4.5	Set Time Format.....	31
4.6	Set Password	31
4.7	Set Language.....	32
4.8	Units	32
4.9	Alarm Relay	32
4.10	About.....	32

5.0	CONTROLLER SET-UP	33
5.1	General Information.....	33
5.2	Configure Data Set.....	33
5.2.1	State.....	34
5.2.2	Name.....	34
5.2.3	Control Model.....	34
5.2.4	Flow Monitor.....	34
5.2.5	Flow Object	34
5.2.6	Active Flow State.....	34
5.3.	Control Model Menu	35
5.3.1	Cooling Tower Control.....	35
5.3.1.1	State	35
5.3.1.2	Conductivity Probe	35
5.3.1.3	Limit Time	35
5.3.1.4	Control Delay	35
5.3.1.5	Alarm Delay	36
5.3.1.6	Set Point	36
5.3.1.7	Relay	36
5.3.1.8	High Control	36
5.3.1.9	High Alarm.....	36
5.3.1.10	High Alarm Email	36
5.3.1.11	Limit Time Email.....	37
5.3.1.12	Low Alarm	37
5.3.1.13	Low Alarm Email	37
5.3.2	Boiler Control	37
5.3.2.1	State.....	37
5.3.2.2	Conductivity Probe	37
5.3.2.3	Wait Time	37
5.3.2.4	Sample Time	38
5.3.2.5	Hold Time.....	38
5.3.2.6	Bleed Time	38
5.3.2.7	Limit Time.....	39
5.3.2.8	Set point	39
5.3.2.9	Relay	39
5.3.2.10	High Control	39
5.3.2.11	High Alarm	39
5.3.2.12	High Alarm Email	39
5.3.2.13	Limit Time Email	40
5.3.2.14	Low Alarm	40
5.3.2.15	Low Alarm Email	40
5.3.3	Process Cntrl.....	40
5.3.3.1	Probe 1 Control	40
5.3.3.1.1	State.....	40
5.3.3.1.2	Probe.....	40
5.3.3.1.3	Set point	40
5.3.3.1.4	High Control State	41
5.3.3.1.4.1	High Control	41
5.3.3.1.4.2	High Alarm.....	41
5.3.3.1.4.3	High Alarm Email.....	41
5.3.3.1.4.4	High Relay.....	41
5.3.3.1.4.5	High Limit Time Email	42

5.3.3 1.5	Low Control State	42
5.3.3 1.5.1	Low Control	42
5.3.3.1.5.2	Low Alarm	42
5.3.3.1.5.3	Low Alarm Email	42
5.3.3.1.5.4	Low Relay.....	42
5.3.3.1.5.5	Low Limit Email	43
5.3.3.1.6	Control Delay.....	43
5.3.3.1.7	Limit Time.....	43
5.3.3.1.8	Alarm Delay.....	43
5.4	Clearing Alarms	43
5.4.1	View Alarms	43
5.5	Chemical Feed Timers	44
5.5.1	Bleed and Feed.....	44
5.5.2	Percent Post-Bleed	44
5.5.3	Percent.....	44
5.5.4	Pulse Mode	44
5.5.5	28 Day	44
5.6	Setting the Weekly Calendar Timer.....	45
5.6.1	State	45
5.6.2	Relay	45
5.6.3	Type	45
5.6.4	Schedule	45
5.6.5	Months: View/Edit.....	45
5.6.6	Weeks: View/Edit	45
5.6.7	Days: View/Edit	45
5.6.8	Next Run:	45
5.6.9	Start Time: View/Edit.....	45
5.6.10	Run Time.....	45
5.6.11	Lockout Timer:.....	46
5.6.12	Prebleed:.....	46
5.6.13	Prebleed Point:.....	46
5.6.14	Prebleed Limit Timer	46
5.6.15	Prebleed Limit Email	46
5.7	Setting the Daily Calendar.....	46
5.7.1	State	46
5.7.2	Relay	47
5.7.3	Type	47
5.7.4	Schedule	47
5.7.5	Months: View/Edit	47
5.7.6	Days: View/Edit	47
5.7.7	Next Run:	47
5.7.8	Start Time: View/Edit.....	47
5.7.9	Run Time:.....	47
5.7.10	Lockout Timer:.....	47
5.7.11	Prebleed:.....	47
5.7.12	Prebleed Point:.....	48
5.7.13	Prebleed Limit Timer	48
5.7.14	Prebleed Limit Email	48
5.8	Setting the Bleed and Feed Timer.....	48
5.8.1	State	48
5.8.2	Relay	48
5.8.3	Type	48

5.8.4	Limit Timer (Bleed)	48
5.9	Setting the Pulse Mode Timer	49
5.9.1	State	49
5.9.2	Relay	49
5.9.3	Type	49
5.9.4	Water Meter.....	49
5.9.5	Pulse Mode Gallons	49
5.9.6	Remaining Gallons	49
5.9.7	Pulse Mode Time	49
5.10	Setting the Percent Post-Bleed Timer	49
5.10.1	State	49
5.10.2	Relay	50
5.10.3	Type	50
5.10.4	Post Bleed:	50
5.10.5	Limit Time:	50
5.11	Setting the Percent Timer.....	50
5.11.1	State	50
5.11.2	Relay	50
5.11.3	Type	50
5.11.4	Cycle time:.....	50
5.11.5	Cycle %:	50
6.0	SYSTEM CALIBRATION	51
6.1	Introduction.....	51
6.2	Calibration Q and A	51
6.2.1	What does Calibration do	51
6.2.2	How do you Calibrate	51
6.2.3	How does Calibration work?.....	51
6.3	Configure Object	51
6.3.1	Renaming the Object.....	52
6.4	Calibrating Probes.....	52
6.4.1	1-Point Calibration.....	52
6.4.2.	2-Point Calibration.....	53
6.5	Boiler Calibration Notes.....	54
6.6	Conductivity Function Calibration Notes	55
6.7	pH Function Calibration Notes	55
6.8	ORP Function Calibration Notes	55
6.9	MPIO (Multi-Purpose Input/Output IntelliSense)	56
6.9.1	Configuring Your MPIO Intellisense	56
6.9.1.1	Name	56
6.9.1.2	Service	56
6.9.1.3	Water Input.....	56
6.9.1.3.1	Dry Contact	56
6.9.1.3.1.1	Gallons/Pulse	57
6.9.1.3.2	Hall Effect.....	57
6.9.1.3.2.1	K-Factor.....	57
6.9.2	Reset	57
6.9.3	4-20 mA Input Setup and Calibration	57
6.9.3.1	4-20mA In Type.....	57
6.9.3.2	4-20mA In Scale.....	58
6.9.3.2.1	Low Current.....	58
6.9.3.2.2	Low Value.....	51

6.9.3.2.3	High Current	58
6.9.3.2.4	High Value	58
6.9.3.2.5	4-20mA In Power:On/Off	58
6.9.4	4-20 mA Output Setup and Calibration	58
6.9.4.1	4-20mA Out Src (source)	59
6.9.4.2	4-20mA Out Scale(View/Edit).....	59
6.9.4.2.1	Low Current.....	59
6.9.4.2.2	Low Value.....	59
6.9.4.2.3	High Current.....	59
6.9.4.2.4	High Value.....	59
6.9.4.2.5	4-20mA Out Power:On/Off	60
6.10	Water Meters (Onboard)	60
6.10.1	Water Input.....	60
6.10.1.1	Dry Contact	60
6.10.1.1.1	Gallons/Pulse	60
6.10.1.2	Hall Effect.....	60
6.10.1.2.1	K-Factor.....	60
6.10.2	Reset.....	60
7.0	MAINTENANCE.....	61
7.1	Service Schedule Setup	61
7.1.1	Service Alarm	61
7.1.2	Service Days	61
7.1.3	Last Service.....	61
7.1.4	Next Service	61
7.2	Service Alarm Reset.....	61
7.2.1	View Service.....	61
7.3	Conductivity Probe removal and cleaning	62
7.3.1	To remove a conductivity probe from its tee for cleaning.....	62
7.3.2	To re-install a conductivity probe.....	62
7.3.3	To clean a Stainless Steel conductivity probe.....	62
7.4	Boiler Probe removal and replacement	63
7.5	Boiler Probe cleaning	63
7.6	pH Probe information	63
7.6.1	Preparation.....	63
7.6.2	Probe Storage	64
7.6.3	Probe Cleaning.....	64
7.7	ORP Probe Information	64
7.7.1	ORP Maintenance and Troubleshooting	64
7.7.2	Testing ORP Probe	65
7.8	Flow Switch	65
8.0	FACTORY INITIALIZE.....	66
9.0	FACTORY DEFAULT VALUES.....	67
10.0	TROUBLE SHOOTING	69
11.0	PROBE DIAGRAMS	74
12.0	SPECIFICATIONS	80

12.1	General.....	80
12.2	Conductivity (2-Wire).....	80
12.3	Conductivity (High Pressure/Temperature).....	81
12.4	Conductivity (Toroidal)	81
12.5	pH.....	81
12.6	ORP.....	81
12.7	Summary of Soft Keys.....	82
12.8	Summary of LED Indicator Lights.....	82
13.0	OPTIONAL EQUIPMENT	83
13.1	IntelliScan (Calibrator).....	83
13.1.1	Specifications	83
13.1.2	Battery Installation.....	84
13.1.3	Probe Installation.....	84
13.2	IntelliScan Setup	84
13.2.1	Set Date	84
13.2.2	Set Time	84
13.2.3	Set Date/Time Format	84
13.2.4	Calibrate the Calibrator	84
13.2.5	Set Language	85
13.2.6	Set Temp. Format	85
13.2.7	Set LCD Contrast	85
13.3	Using your Intelliscan to Calibrate your Intellisense.....	85
13.3.1	Intelliscan System Calibration	85
13.4	Relay Expansion Box	86
13.4.1	Installation	86
13.4.2	Installing USB/Cat 5E cables to Relay Box	86
13.4.3	Installing USB/Cat 5E cables to Controller	86
13.4.4	Setup	87
13.5	USB Hub	88
13.5.1	Installation	88
13.5.2	Installing USB cables from Intellisense to USB Hub	88
13.5.3	Installing USB cables to the Controller	88
13.5.4	Setup	89
14.0	Alarm Information	90
15.0	Glossary	92
16.0	Menu Map.....	95

CONVENTIONS

For the remainder of this bulletin, the following conventions are in effect.

 WARNING	A WARNING DEFINES A CONDITION THAT COULD CAUSE DAMAGE TO BOTH THE EQUIPMENT AND THE PERSONNEL OPERATING IT. PAY CLOSE ATTENTION TO ANY WARNING.
--	--

 NOTE	Notes are general information meant to make operating the equipment easier.
---	---

 TIP	Tips have been included within this bulletin to help the operator run the equipment in the most efficient manner possible. These “Tips” are drawn from the knowledge and experience of our staff engineers, and input from the field.
--	---

STANDARDS

The following standards have been developed to make using this manual easier. Formatting certain sections of text so that they stand out from the main body, alerts the user that there is some item of interest within a specific paragraph by drawing the users attention to:

- Text that has been formatted ***bold*** and ***italicized*** (e.g., ***Section 7, Maintenance***) indicates reference text.
- Text that has been formatted in UPPER CASE letters, and surrounded by brackets [] indicates a “soft” key to be pressed for example: [ENTER] .
- Text that has been formatted in UPPER CASE letters, using the **Arial - Bold** Font indicates a menu selection (e.g., **CALIBRATION**).

1.0 INTRODUCTION

- Your process control instrument has been designed to monitor and control the quality of your processes. The successful operation of this equipment depends on you. This manual is written to help you in this effort.
- There are two important terms that you need to familiarize yourself with in order for you to understand how your instrument controls a process. These are **Set Point** and **Control Point**. The **Set Point** is where you want your process to be, e.g., a pH level of 7. The **Control Point** is the value that you do not want exceeded, e.g., a pH of 8. If the pH reading in this example is rising and reaches the 8 pH value (the **Control Point**), an output relay will be activated and remain activated until the pH level falls to 7 pH (the **Set Point** value). This example is assuming that the unit was setup for a **rising** Set Point. A **falling** set point is an available option.
- For your convenience, there is an abbreviated instruction and software “MENU MAP” supplied with all manuals, to be kept with the controller. This card is not a substitute for this instruction manual. It is supplied as a quick reference only and should be used in conjunction with the instruction manual.

1.1 DESCRIPTION

Models with Conductivity control are designed to monitor and control Total Dissolved Solids (TDS), in terms of electrical conductivity measured in micro Siemens per centimeter ($\mu\text{S}/\text{CM}$). A Control Point of the desired conductivity upper limit is entered into the controller via the front keypad. As this maximum limit is reached, an output relay is activated. In a Cooling Tower or a Boiler, this is wired to a blow down valve. (A built in limit timer can also be set-up to activate an alarm if the system over-bleeds.) The system water with higher levels of TDS is blown down resulting in fresh make-up water being added, reducing the concentration of TDS in the system. When the Set Point value that you entered is reached, the blow down relay is de-energized. The design also includes a High Alarm option with a relay output.

Models with pH control, monitor and control pH by adding acid and/or caustic based on a set point and control point entered into the controller via the front keypad. The pH control has a built in limit timer that acts as a fail safe to prevent system overfeed. The design also includes a High/Low pH Alarm with an optional relay output.

Models with ORP control, monitor and control the addition of chlorine or bromine. The set point and control point are entered into the unit via the front keypad. A limit timer is included to prevent system over feed. The design also includes a High/Low ORP Alarm with an optional relay output.

All models include multiple Selectable Timers that allow the user to choose 1 of 5 timer modes on which to base the addition of chemicals. These timer types are:

- Calendar
- Bleed and Feed
- Pulse Mode
- Percent Post Bleed
- Percent

A mounted flow assembly with quick release probe(s), flow switch and sample cock is an available option providing for the ease and convenience of installation and to facilitate periodic maintenance and sampling. A flow switch disables the outputs of the controller when flow is discontinued in the flow assembly.

An onboard lithium battery provides back-up for system settings when power is lost. Hand/Off/Auto keys are provided on the keypad for immediate control of pumps, solenoid valves, etc., without having to scroll through display menus.

2.0 INSTALLATION

2.1 LOCATION

Select a mounting location convenient to grounded electrical and plumbing connections. Mount the controller on a wall or other vertical surface with adequate lighting at a comfortable level. Avoid locations where the controller would be subjected to extreme cold or heat. Installation should comply with all national, state and local codes.

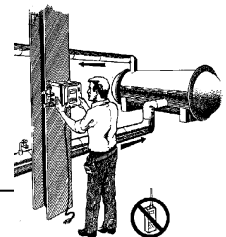

AVOID LOCATIONS WHERE THE CONTROLLER WOULD BE SUBJECTED TO EXTREME COLD OR HEAT {LESS THAN 0°F (-17.8°C) OR GREATER THAN 122°F (50°C)}, DIRECT SUNLIGHT, VIBRATION, VAPORS, LIQUID SPILLS OR EMI

(ELECTROMAGNETIC INTERFERENCE; I.E., STRONG RADIO TRANSMISSION AND ELECTRIC MOTORS.)

NOTE: SOME COMPONENTS SHOWN ARE OPTIONAL

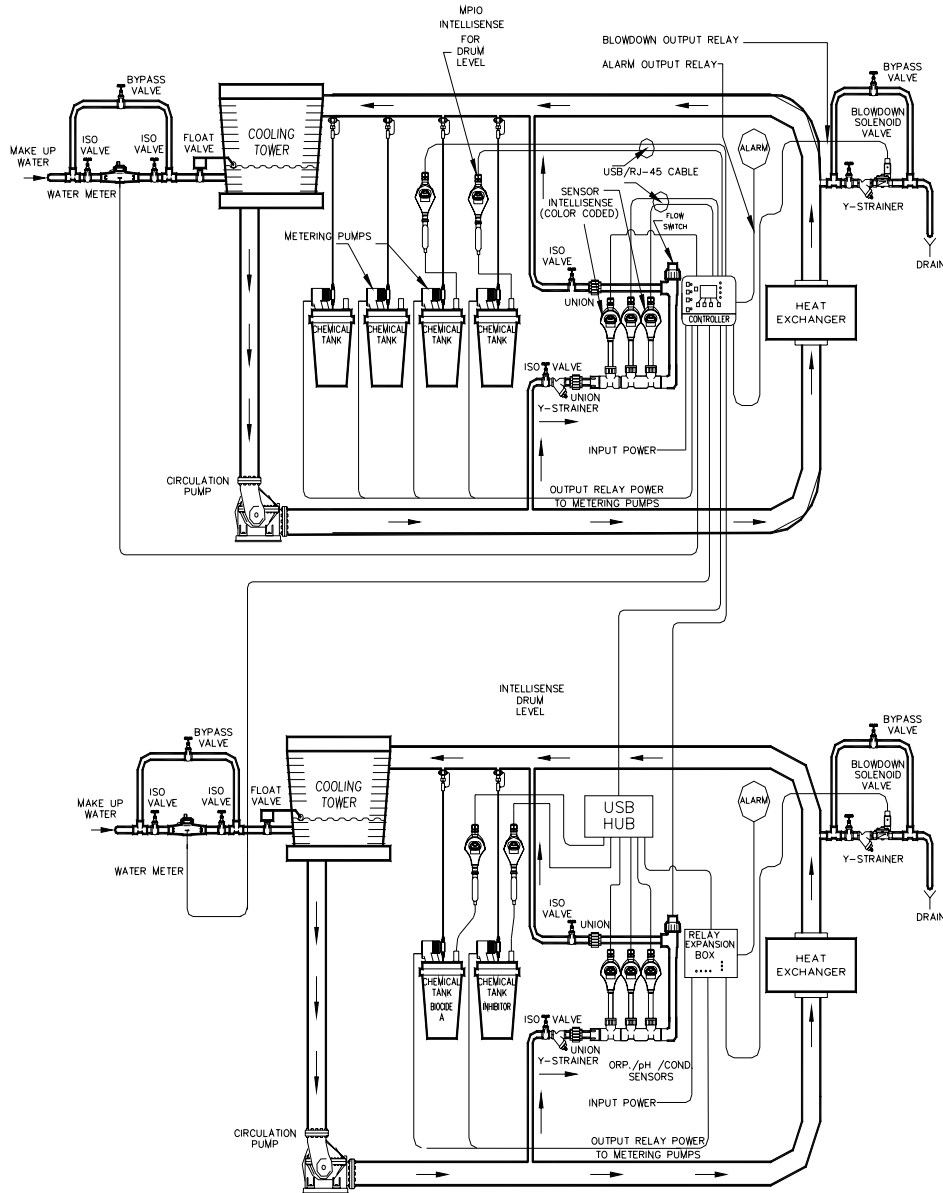

Figure 1 – Typical Dual Cooling Tower Installation



NOTE

The optional flow assembly, is 3/4 inch piping.

TIMED SAMPLE

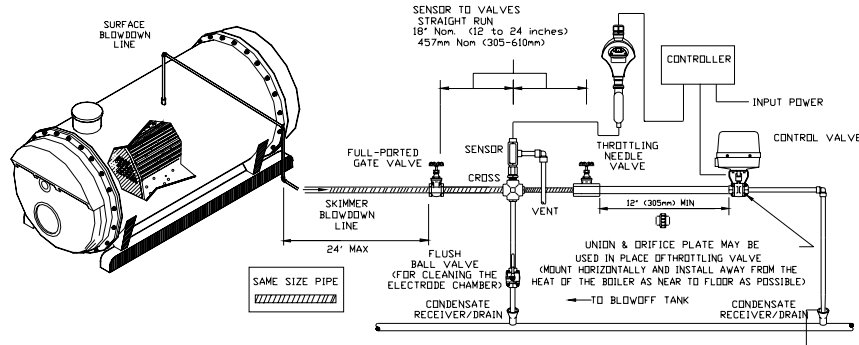

CONTINUOUS SAMPLE

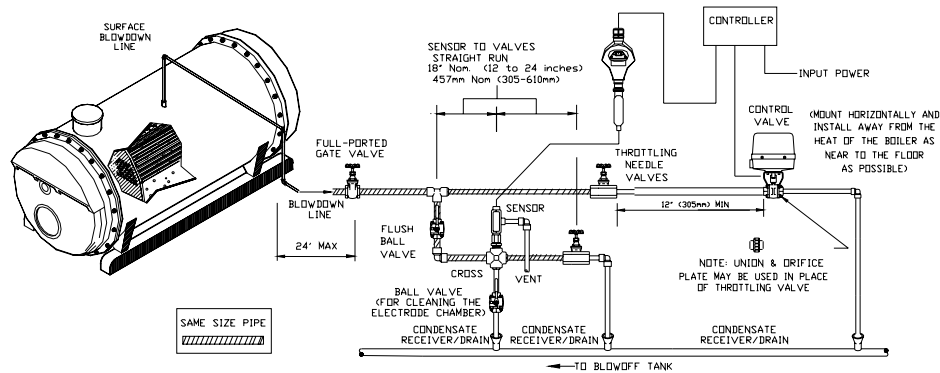

Figure 2 – Typical Boiler Installations

2.2 INSTALLATION NOTES



Always power down your system (this includes all accessories) before adding objects via USB/CAT 5E cables to your network

- Install probes or sample stream flow assembly at some point before chemical injection points where chemical and water are thoroughly mixed (see *Figure 1*).
- Measuring surfaces of the probe electrodes must be continuously immersed in system water.
- The difference between the inlet and output pressure must be sufficient to provide a flow rate between 1 to 5 GPM (3.81 to 19.05 l/m) to assure water will flow past the probes and they will read properly.



IMPORTANT! A pressure differential must exist between the input and output for proper flow

- Install strainer on the upstream side of the flow assembly to collect debris that might affect controller operation. Install unions on both the inlet and outlet (see *Figure 1*).
- Install hand valves on each side of the flow assembly for easy isolation, flow throttling, and removal of probes and strainer screens (see *Figure 1*).
- Direction of flow should be from the bottom to the top of the flow assembly so flow monitoring switch will operate properly (see *Figure 1*).
- A manual valve should be installed in the blow down line on the system side of the solenoid valve. This will be used for isolating and throttling (controlling the flow rate of blow down) if blow down is incorporated (see *Figure 1*).
- Most solenoid valves require a pressure differential of 7 psi (0.48 BAR) to 15 psi (0.96 BAR) to close; if this is not available, install a zero pressure solenoid valve if blow down is incorporated.
- Always install a strainer upstream of the solenoid valve (to collect debris that may clog solenoid valve) if blow down is incorporated (see *Figure 1*).
- For proper operation and accuracy, install water meters horizontally with meter face up if Pulse Timer mode is used.



IMPORTANT! Water meter installation - A horizontal length equivalent to at least 12 pipe diameters must precede the water meter inlet and a horizontal pipe length of 6 diameters must follow it. All piping in this area must be of the same diameter.

- If chemicals are to be injected into sample line (not recommended), always use a back check valve to prevent chemicals from backing up around probes.
- If a flow assembly or sample stream assembly is present, never install a blow down valve off these lines. The system will not achieve proper blow down and accuracy of controller readings may be affected.
- Refer to the next section for probe installation. After installation of all probes check all connections. Then open the isolation valves and check for leaks.

2.2.1 PROBE INSTALLATION (IN-LINE)

- System set-up should be per installation diagram (see *Figure 1*). Make sure all fittings and connections are secure:
- Remove power from the controller.
- Close isolation hand valves located before and after the flow assembly.
- Open the sample port on flow assembly to make sure no flow is present in the flow assembly.
- Remove coupling nut from probe housings on flow assembly.
- If your controller is equipped with a pH or ORP probe, remove the liquid filled protective cover from the probe tip.



EXERCISE CARE WHEN REMOVING THE PROTECTIVE COVER FROM THE pH OR ORP PROBE. DO NOT HIT THE TEE OR OTHER PIPING WITH THE GLASS BULB (IF EQUIPPED). NEVER EXPOSE THE PROBE TO AIR WITH POWER ON FOR MORE THAN 45 SECONDS. NEVER ALLOW THE PROBE TO DRY OUT.

- Loosen the cap by twisting prior to removal. Save the protective cap for future storage.
- Use supplied cover filled with proper storage solution. (see *Figures 3&5*). See **Section 7 - Maintenance** for more information
- Make sure that the o-ring is still seated on the probe housing.
- Slip coupling nut over probe. Gently install probe into probe housing on flow assembly. Make sure probe is firmly seated in housing. (*Figure 3*)
- Slip coupling nut down onto housing threads and hand tighten.
- Make sure sample port on flow assembly is closed. Next apply pressure and flow by opening hand valves slowly to avoid water hammer.
- Refer to **Section 8** for information and specifications of probes supplied with your system.

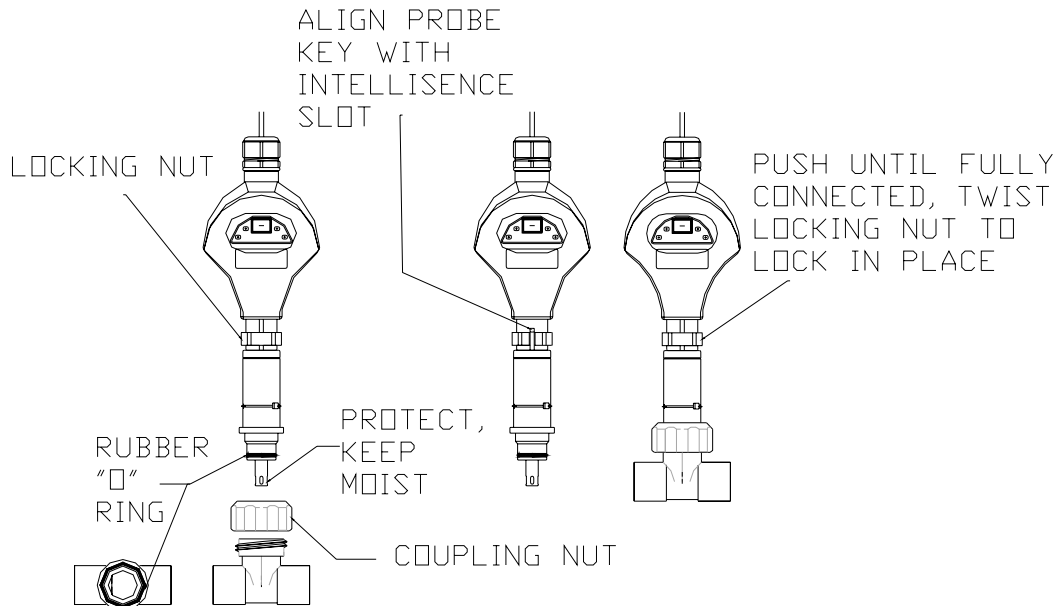

Fig. 3 Diagram of probe hat installation

- The probes are used in conjunction with a color-coded *IntelliSense* interface. This interface is an analog to digital converter that transmits the probe data to the main unit via a USB or CAT 5E, CAT 5E cable.
- To attach the probe to the *IntelliSense*, turn the locking ring so that its gap faces front. Next, insert the DIN connector mounted on top of the probe into the bottom of the *IntelliSense* making sure that the tab aligns with the bottom front slot. Secure the assembly by rotating the locking ring. To separate the probe and the *IntelliSense*, reverse the above process.



The *IntelliSense*'s color signifies the type of probe to attach.
(Fig.3b)

**** INTELLISENSE COLOR CODES ****

Light Grey is for 2 wire conductivity probes

Blue is for pH probes

Red is for ORP probes

Orange is for multipurpose Input/Output (MPIO *IntelliSense*)

Dark Gray is for toroidal conductivity probes

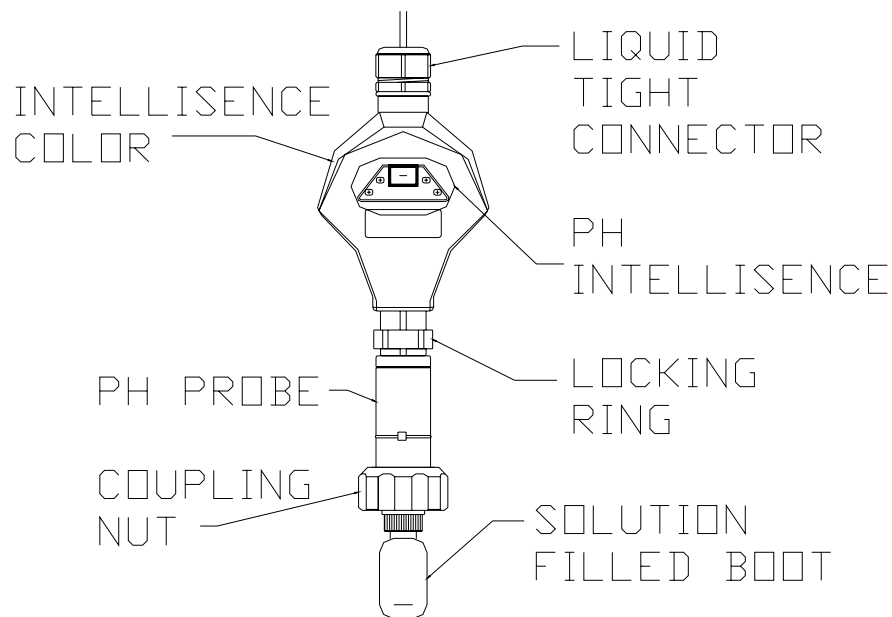

Fig.3b - IntelliSense with pH Probe attached



Do **NOT** allow pH and ORP probe tips to dry out. However, make sure to **remove** the protective probe **boot** before installing into the flow



NEVER apply power to a pH or ORP probe that is not wet. This will damage the probe

2.2.2 PROBE INSTALLATION (SUBMERSIBLE)

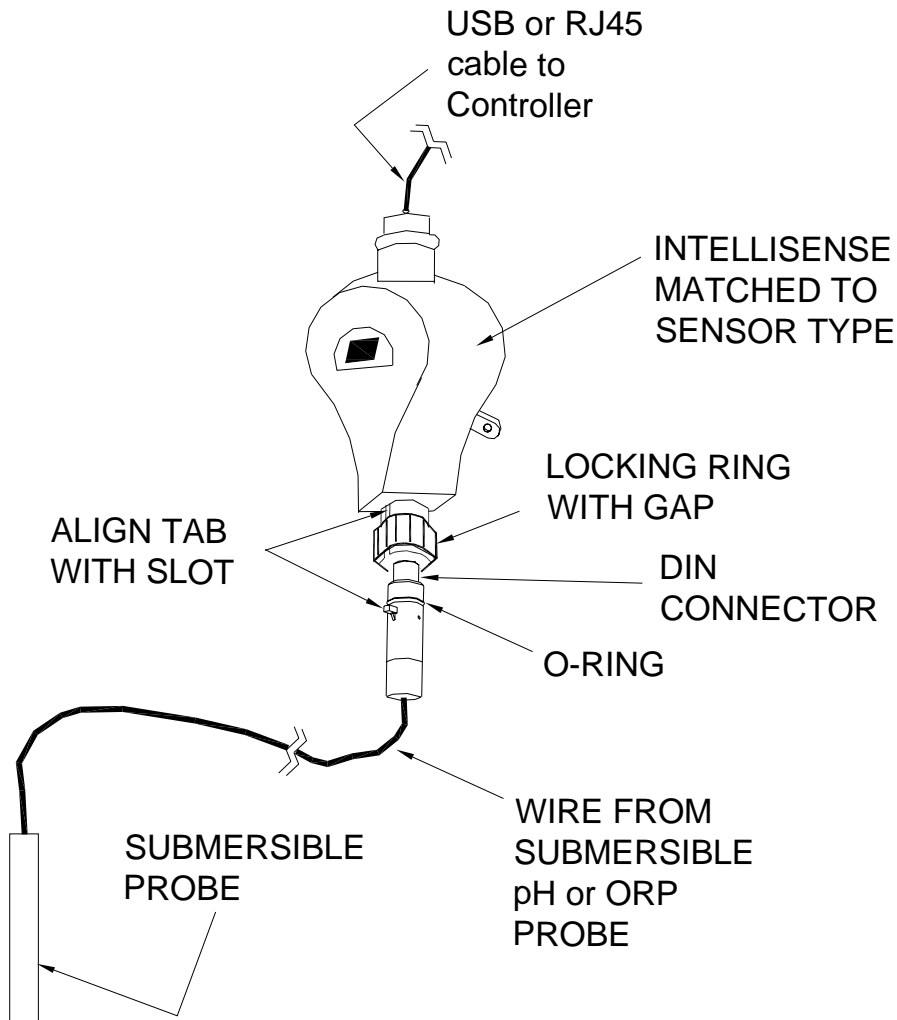

Fig. 4 Submersible probe installation

- To attach pH and ORP submersible probes to an IntelliSense, turn the locking ring so the gap faces the front. Next, insert the DIN connector on the end of the probe cable into the bottom of the IntelliSense, making sure that the tab aligns with the front slot. Be sure that the O-ring seal stays in position. Secure the connector by rotating the locking ring. To remove the probe, reverse the process.

2.3 USB CABLE TO CAT5 CABLE ADAPTER



NOTE

IMPORTANT! USB cables are limited to 15 ft. (4.6 m). A Cat 5E cable must be used if the probe is over 15 ft. (4.6 m) from the process control instrument. The maximum distance is 1000 ft. (304.8 m). You must use a USB to RJ45 Adapter (Part No. DA01-1001) to change the RJ45 to USB before connecting it to your controller's USB ports. The adapter is connected to the circuit board inside the instrument. (See Fig 5)

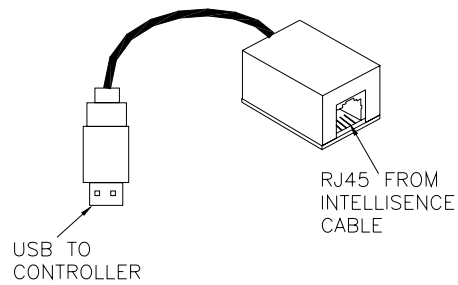
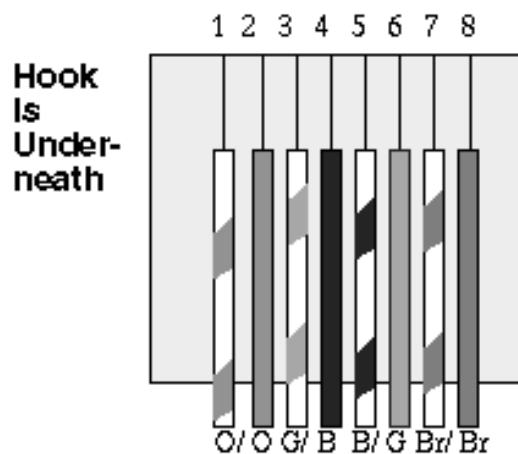

Fig.5 – USB to RJ45 Adapter

2.3.0 RJ45 CONNECTOR WIRING

T-568B Color Code for RJ-45 Plug



Eight-conductor data cable contains 4 pairs of wires. Each pair consists of a solid (or predominantly) colored wire and a white wire with a stripe of the same color. The pairs are twisted together. To maintain reliability on Ethernet, you should not untwist them any more than necessary (about 1 cm).

Pin Number Designations

There are pin number designations for each color in T568B as well. The pin designations are as follows:

Color Codes for T568B

Pin	Color	Pair	Name
1	white/orange	2	TxDData +
2	orange	2	TxDData -
3	white/green	3	RecvData+
4	blue	1	
5	white/blue	1	
6	green	3	RecvData-
7	white/brown	4	
8	brown	4	



The odd pin numbers are always the white with stripe color.

2.3.1 BOILER CONDUCTIVITY PROBE INSTALLATION

- Close isolation hand valves located before and after the sensor.
Open the ball valve to drain water from the sensor housing; to insure no water or pressure is present in this part of the assembly
- Apply six wraps of Teflon tape to threads of the sensor. Install a nipple and union if not already installed
- Install the sensor into the Cross housing. Make sure that the flats on the sensor line up perpendicular with the piping run.
- Tighten all connections. Do not over-tighten.
- Close the flush valve. Open the isolation valve up-line from the sensor slowly to prevent water hammer. Carefully inspect for leaks.

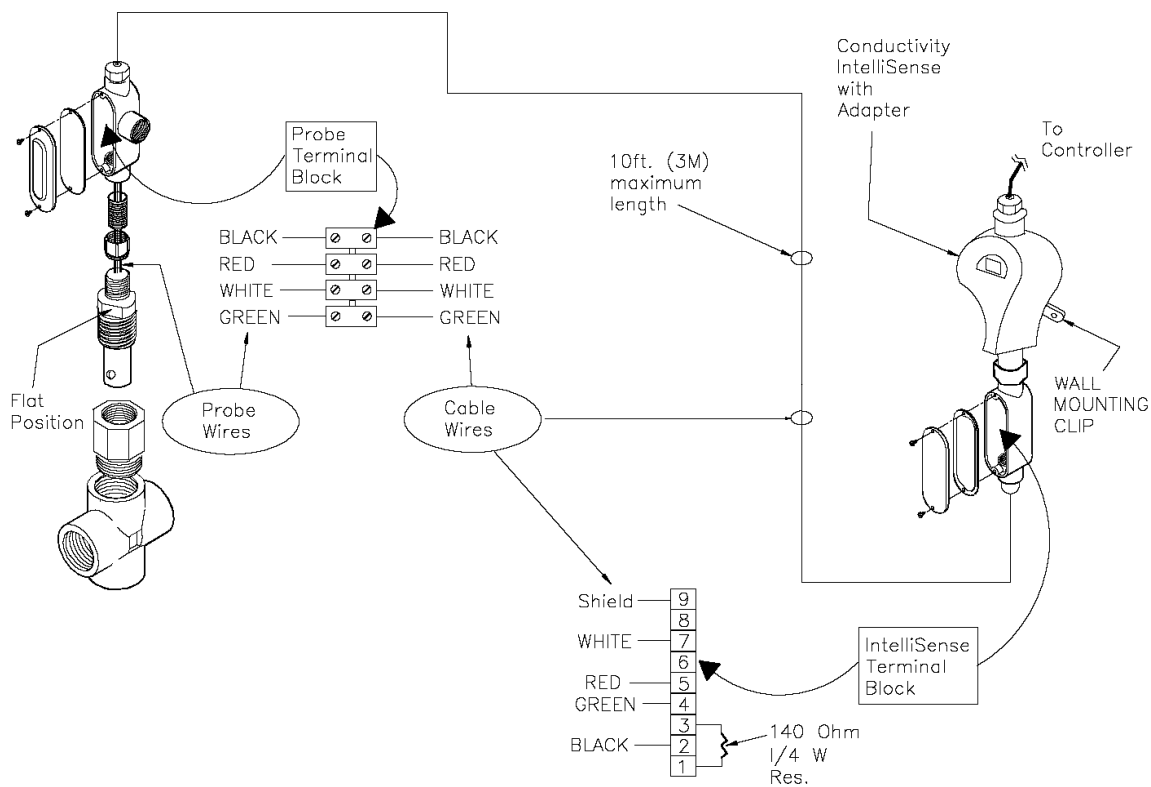

Fig. 6 Boiler probe

2.3.2 INSTALLING THE INTELLISENSE

Select a location to mount your *IntelliSense* so you have easy access to the front IR window. Use the clips for wall mounting with #10 screws. These clips simply slide into two slots located on the back cover of the *IntelliSense*. Make sure that the *IntelliSense* is not exposed to excessive temperatures.

2.3.3 INSTALLING BOILER PROBE CABLE TO THE INTELLISENSE ADAPTER

The cable between the probe terminal block and the *IntelliSense Adapter* can be no longer than 10 ft. (3.04 m).

- Loosen the grey compression nut from the liquid tight connector located on the bottom of the *IntelliSense Adapter*.

- Remove the 2 screws and remove the grey Adapter cover to access the terminal block.
- Slip the wire through the liquid tight connector.
- Cut to length and strip the wires and connect the wires to the terminal block in the following manner:
 - 2 - BLACK
 - 4 - GREEN
 - 5 - RED
 - 7 - WHITE
 - 9 - SHIELD



There must be an identifying 140 ohm, ¼ W., 1% resistor between terminals 1 and 3. The probe will not function without this resistor.

2.4 INSTALLING USB/CAT 5E CABLES TO THE INTELLISENSE

Each *IntelliSense* has either a USB or RJ45 input connector located on top behind a liquid tight connector. To make this connection, follow these instructions:

- Unscrew the liquid tight connector from the top of the *IntelliSense*.
- Remove the outside compression nut from one of the large liquid tight connectors.
- Pass your USB/CAT 5E cable through the outside nut and put aside. Remember that you will be replacing this nut so please note orientation of the nut.
- Using a finger, push out the white plug. Note that the plug has a hole and is cut to allow for the cable to be slipped through. Also, note the orientation of the plug.
- Pass the cable connector through the compression nut and the liquid tight connector.
- Plug the cable into the *IntelliSense* connector.
- Replace the liquid tight connector.
- Slip the cut white rubber plug over the cable noting the orientation, cupped side toward the connector and slid it back into the liquid tight connector. This may take some effort to clear the plastic tabs. Make sure that the plug is fully seated.
- Replace the compression nut.



If your system has a pH or ORP probe and a conductivity probe, make sure that the conductivity probe is installed downstream.

2.5 INSTALLING USB/CAT 5E CABLES TO THE CONTROLLER

Your process control instrument has 3 USB inputs for attaching probes and accessories. These are located behind the front panel.

- Remove the 4 panel screws and set aside.
- Lift off the front panel and place it face down above the box.
- Remove the outside compression nut from one of the 3 large liquid tight connectors.
- Pass your USB/CAT 5E cable through the outside nut and put aside. Remember that you will be replacing this nut so please note orientation of the nut.
- Remove the plastic rod sealing a white rubber plug.
- Using a finger, push out the white plug. Note that the plug has a hole and is cut to allow for the cable to be slipped through. Also, note the orientation of the plug, cupped side toward the controller.

- Slip the plug onto your cable allowing about 12 in. (30.5 cm.) of slack. Make sure that the plug is in the same orientation.
- Pass the cable connector through the liquid tight and replace the rubber plug. This may take some effort to clear the plastic tabs. Make sure that the plug is fully seated.
- Replace the compression nut.
- Next, plug your cable into one of the 3 available USB ports.
- Remember that if you have a CAT 5E cable, a **USB to RJ45 Adapter** (Fig. 7) must be used to convert the cable to USB.
- Replace the front panel and insert the 4 screws.
- Repeat the above process for the other USB ports.

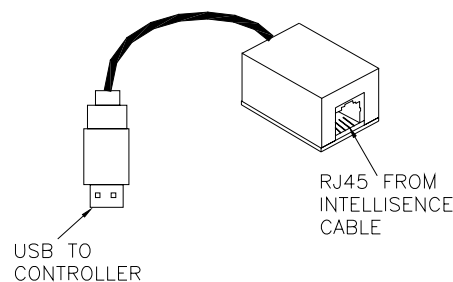

Fig. 7 USB to RJ45 Adapter

2.6 ACCESSORIES (not included)

The following accessories are suggested to complete the installation.

- Two manual gate valves, one on each side of the probe/flow assembly, to isolate the probe/flow assembly for installation and routine maintenance.
- One needle valve, for isolating and throttling the blow down flow rate.
- Three manual gate valves, for isolating, bypassing and maintenance of water meter, if controller incorporates a water meter (optional).
- Solenoid valve for blow down (bleed).
- Two Y-strainers, one before solenoid valve and the other before the flow assembly.
- Chemical metering pumps as required.
- Water meter(s)
- External alarm.

2.7 ELECTRICAL WIRING



UNIT MUST BE WIRED IN ACCORDANCE WITH ALL APPLICABLE ELECTRICAL CODES.

The process control instrument electronic input circuitry is fuse protected on both the hot and neutral inputs using a replaceable plug-in five amp fuse. In addition, each output relay is individually protected by a replaceable plug-in 5 amp fuse on the I/O board (refer to **Fig.9**).

For additional protection of your instrument, use of a surge protector is recommended. The device should satisfy the following minimum requirements:

Response:	<1ns
Energy Dissipation:	400 Joules
EMI/RFI Noise Attenuation:	5-35dB



NOTE

The controller should be connected to its own 15 amp power branch (i.e., its own wiring, circuit breaker, etc.). For best results, the ground should be independent (true earth) not shared.

Pre-wired units are supplied with a 6 ft (1.8 m), 16 AWG (1.2 mm²) 3-wire grounded power cord and 18 AWG (1.2 mm²) 3-wire grounded receptacle cords for all controlled line voltage outputs.

Conduit units have openings for conduit connections for hard wiring. (See **Fig. 9**) for input and output power connections. Use only 16 AWG (1.5 mm²) or 18 AWG (1.2 mm²) wire for conduit power and load connections.

Use 22 AWG (.76 mm²) wire for water meter(s). These signal wires must be run separate from AC power lines.



NOTE

Liquid Tight fittings are provided for all signal leads.

2.7.1 User Connections

When connections are required by the end user, follow the instructions below:



WARNING

LINE VOLTAGE IS PRESENT ON THE POWER SUPPLY LOCATED BEHIND THE FRONT PANEL. LINE VOLTAGE IS ALSO PRESENT ON THE I/O BOARD LOCATED IN THE BOTTOM OF ENCLOSURE, EVEN WHEN POWER IS OFF. POWER MUST BE DISCONNECTED WHILE CONNECTIONS ARE BEING MADE!

2.7.1.1 Open The Enclosure

Loosen the four (4) screws from the bottom cover and remove.

Connect the incoming power to .25 in. spade terminals labeled P3, P4, and P5 on the I/O board located at the bottom of the enclosure. Connect the Neutral to the position labeled 'RTN.' Connect the Earth Ground to the position labeled with the earth ground symbol. Connect the Line to the position labeled 'HOT.' Use only 16 AWG (1.5 mm²) wire.

2.7.1.2 Relay Connections

Relay connections are made via .25 in. spade terminals on the I/O board. Use only 16 or 18 AWG (1.5mm² or 1.22mm²) wire. Both normally open and normally closed powered contacts are available (Fig. 8). Many motorized ball valves require connections to both the Normally Open (N.O.) and Normally Closed (N.C.) terminals (Refer to **Fig.9** for further wiring details). Relay associations are made via software (refer to Section 5, Controller Setup).

RELAY #1		RELAY #2		RELAY #3		RELAY #4		ALARM	
Disc.	Position	Disc.	Position	Disc.	Position	Disc.	Position	Disc.	Position
N.C.	P6	N.C.	P10	N.C.	P14	N.C.	P18	N.C.	P22
N.O.	P7	N.O.	P11	N.O.	P15	N.O.	P19	N.O.	P23
Gnd.	P8	Gnd.	P12	Gnd.	P16	Gnd.	P20	Gnd.	P24
RTN	P9	RTN	P13	RTN	P17	RTN	P21	RTN	P25

Fig. 8

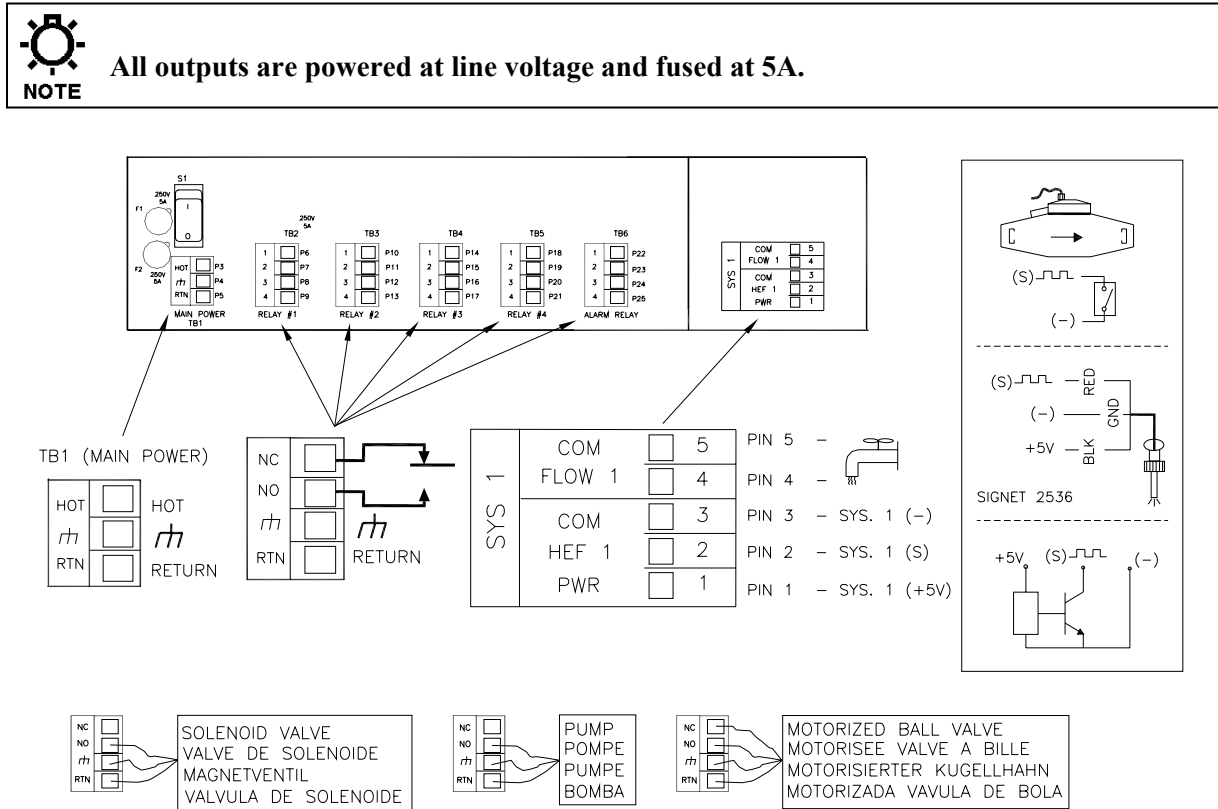

Fig.9 – Input/Output (I/O) Board Electrical Connections

NOTE Pins 1 and 6 (+5VDC) are for Hall effect water meters only. Contacting water meters use Pins 2 and 3 for System 1 and Pins 7 and 8 for System 2.

NOTE For proper rejection of AC line voltage spikes, probe EMI noise rejection and personal safety, the case ground (SAFETY GROUND) must be properly installed. If there is ANY doubt, consult a qualified electrician.

2.7.1.3 Flow Switch or Interlock

It is recommended that a flow switch or auxiliary dry contact from the control panel be used to make outputs inoperative when flow is halted.

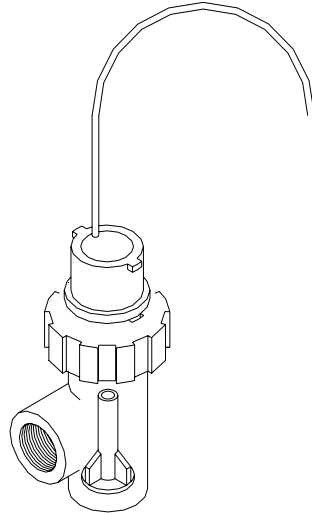

Fig. 10 Flow (detection) Switch Assembly and 2-wire cable.

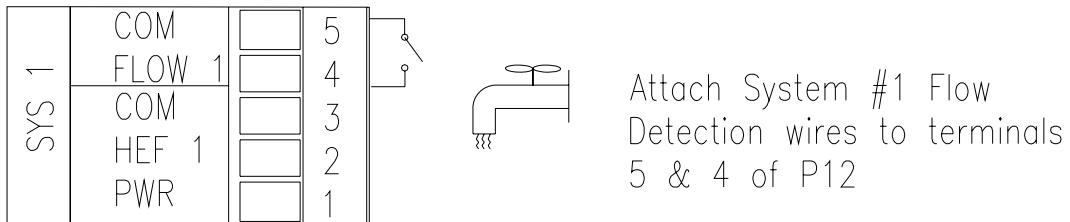

Fig. 10a Flow Detector

2.7.1.4 Water Meter (for Pulse Timer)

Water meters are connected to the I/O Board at the bottom of the enclosure. Refer to (*Fig. 9*) for the water meter connection location. The connections are made to P12.

The Controller can be configured with a meter driving one or more pulse timers. The association is made in software not in hardware. Refer to ***Controller Setup Sec.54*** for further information.

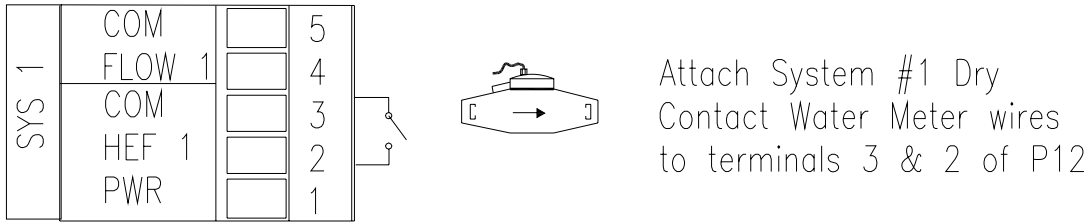

Fig. 11 Water Meter

2.7.1.5 Hall Effect Water Meter

Hall effect water meters are connected to the I/O Board at the bottom of the enclosure. Refer to (*Fig. 9*) for the water meter connection location. The connections are made to P12.

The Controller can be configured with a water meter driving one or more pulse timers. The association is made in software not in hardware. Refer to ***Controller Setup Sec. 5*** for further information.

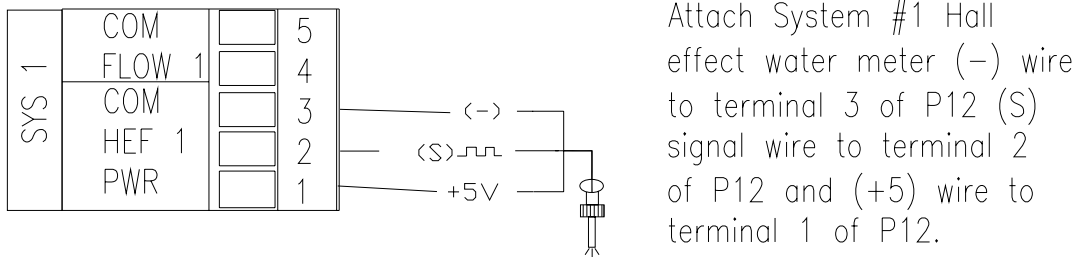

Fig. 12 Hall effect water meter

3.0 START UP INSTRUCTIONS

READ THE FOLLOWING BEFORE PROCEEDING ANY FURTHER!

Power-up



BEFORE APPLYING POWER, INSURE THAT DEVICES BEING CONTROLLED ARE NOT IN A POSITION TO CAUSE HARM OR DAMAGE IF ACTIVATED UPON INITIAL START-UP.

With the controller now installed in a convenient location, supply power to the controller. The power LED indicator light will be illuminated.

BUILDING USB NETWORK will appear on the screen.

During warm up, the controller builds a network of all objects connected.

When the network of objects is complete, the **HOME MENU** is displayed.

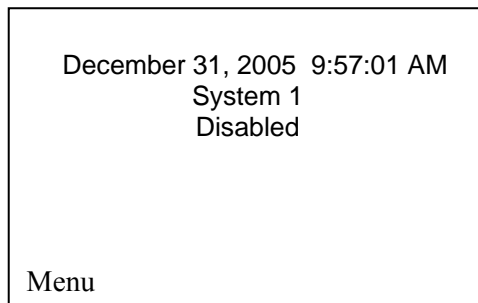

Fig.13

3.1 Front Panel

Take a moment to review *Figure 14*, to become familiar with the controller front panel.

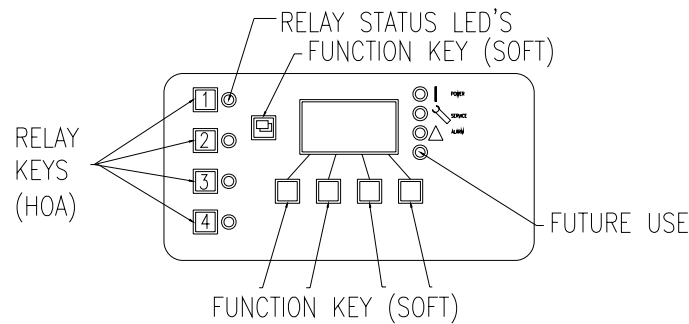

Fig. 14 front panel

3.2 Keypad Operation

Your process control instrument uses five multifunction “soft” keys for navigating through the menus and are used for entering information. Here is a list of key functions:

[Menu] - displays the Main Menu.

[Sys 1]

[ENTER] – has multiple functions. It is used to **select** a highlighted item on the display. It is used to **toggle** between the Disabled and Enabled function. Finally, it is used to **accept an entered value**.

[CHANGE] – Toggles between two choices, e.g., enable/disable.

[^],[v] – Up and Down keys have dual functions. They are used to scroll through menu items and are used to select alphanumeric characters.

[>] - used to move the cursor to the right

[<] - used to move the cursor to the left (used with the SHIFT key.)

[SHIFT] – This key must be held down to use the **Home**, **Cancel** and **Back** keys.

[Home] – Returns unit to **Home Menu** that displays system information.

[Cancel] – Cancels programming and returns unit to previous screen

[Back] – Returns unit to previous screen

- **RELAYS (1-4)** – These Hand/Off/Auto (HOA) keys allow immediate control of the relays powering attached pumps, solenoid valves, etc. Press a [RELAY] key once to force the relay on for 5 minutes (an amber light is displayed below that key). Press the [RELAY] key again to force the relay off (a red LED is displayed below that key, relay will be forced off until the key is pressed again or the power is cycled on the unit). Press the [RELAY] key a third time to return the relay to auto control (green LED will indicate that relay is on, no light indicates that relay is off).



IMPORTANT! Unlike relays 1-4, relay 5 does not have an HOA key and therefore can not be immediately controlled, i.e., forced off by a simple key press.

3.3 Menu Structure

3.3.1 View Alarms

This screen is only displayed when an alarm condition exists. Only current service information is displayed. When the alarm condition clears, the Alarm display does as well. The exception to this is a Limit Timer alarm. This alarm can only be cleared from this screen by pressing the **ClrAlarm** key.

3.3.2 View Service

This screen is only displayed when a service condition exists. Only current alarm information is displayed. After the service is performed, the alarm can be cleared from this screen by pressing the **ClrAlarm** key.

3.3.4 Control Model

This process control instrument can be used in various applications. The software has three system options: Cooling Tower, Boiler, and "Process Cntrl."

3.3.4.1 COOLING TOWER

Your process control instrument is engineered to monitor and control the quality of your cooling tower's water. It can control one or two systems. Note that two systems may require additional components.

Models with **Conductivity control** are designed to monitor and control conductivity in open circulating cooling systems, in terms of electrical conductivity measured in micro Siemens per centimeter (uS/cm). A **Control Point**, the maximum desired conductivity limit is entered into the control instrument via the front keys. As this maximum limit is attained, a blow down valve is opened. (A built-in limit timer, that starts with blow down, can also be set-up to activate an alarm if the system over bleeds.) This alarm can only be cleared by pressing the **ClrAlarm** key. The system water with higher levels of TDS is blown down resulting in fresh water being added, reducing the concentration of TDS in the cooling system. You select which output relay (1, 2, 3, 4 or 5) that will be the Blow down relay(s). The High Alarm output relay also activates when the TDS of the system reaches a high alarm value that you select. The Alarm LED will turn ON and this alarm will be added to the ALARM MENU. When the conductivity reading falls to the **Set Point** value entered via the front keys, the relay is turned off. When the conductivity falls below the high alarm set point, the alarm condition is cleared.

Models with **pH control**, monitor and control pH by adding acid and/or caustic based on a **Control Point** and a **Set Point**. You select which relay will be your pH control relay. The pH control also has a limit timer that acts as a failsafe to prevent overfeed. When the pH reaches the control point, the output relay is energized. When the pH reading equals the Set Point, the relay is switched off. You can program an pH Alarm relay. When the pH level is below the alarm value, the alarm condition is cleared.

Models with **ORP control** monitor and control ORP based on a **Control Point** and a **Set Point**. You select which relay will be your ORP control relay. The ORP control also has a limit timer that acts as a failsafe to prevent overfeed. When the ORP reaches the control point, the output relay is energized. When the ORP reading equals the Set Point, the relay is

switched off. You can program an ORP Alarm relay. When the ORP level is below the alarm value, the alarm condition is cleared.



NOTE

Probe one of this system must be conductivity!!!.



NOTE

The High Alarm relay will de-activate when the reading falls below the High Alarm value. The Alarm state will be cleared from the controller, i.e., the LED will go OFF and Alarm Menu listing will be cleared. The Low Alarm relay will de-activate when the reading rises above the Low Alarm value. The Alarm state will be cleared from the controller, i.e., the LED will go OFF and Alarm Menu will be cleared.



NOTE

IMPORTANT! To prevent instrument damage, flow rates should not exceed 10 gpm (37.9 liters/m) for pH and ORP probes.

Models with **Chlorine Dioxide control** monitor and control the addition of chlorine dioxide. The set point is entered via the keypad and a limit timer is included to prevent overfeed. You select which relay will be your CLO2 control relay. When the CLO2 exceeds the Control Point, the output relay activates.



NOTE

IMPORTANT! For optimum CLO2 readings, the flow rate should be between 10.6 – 15.9 gph (40-60 liters/hr) across the probe.

3.3.4.2 BOILER

Your process control instrument is designed to monitor and control TDS in one or two steam boiler systems in terms of uS/cm. This is done either by a Continuous Sample or by a Timed Sample. (The sample method is determined by your system's requirements (See Fig. 2). Typically, if 5000 pounds of steam per hour is required, a Continuous Sample system should be used.)

In **Timed Sample** mode of operation, a Control Point and a Set Point of the acceptable conductivity limits are entered via the front keys. During Timed Sample operation, the process control instrument opens the Blow Down valve on a timed interval for a preset length of **sample time**. You assign which relay is your Blow Down relay(s). If TDS is below the control point, the valve will close until the next timed sample. If the Control Point (maximum entered value) is attained, the valve will remain open until the solids are reduced to the Set Point value. The systems water with high levels of TDS is blown down while fresh make-up water is added. A Limit Timer can be used to shut down control and activate an Alarm if the boiler over bleeds. A High or Low alarm can be programmed to activate when the TDS reaches the High or Low Alarm Set Point.

A second option within the **Timed Sample** mode is to program the bleed time. The bleed time menu appears automatically once a hold time value is entered. In this case, the unit will blow down for a user-programmed length of time if the control point value is exceeded. This is a helpful feature to use in cases where flashing across the probe is a problem and the user desires to minimize the number of times the blow-down valve will be actuated.

In **Continuous Sample** mode, a small restricted stream of boiler water is continuously directed past the probe. This mode is ideal for large boilers where condensate return is poor. When used in conjunction with a sample cooler, it is also ideal for situations were boiler

operating temperature and pressure exceed the probe rating. When operating in this mode, the controller continuously monitors the boiler water conductivity. When the conductivity reaches the Control Point, a blow down control valve (typically a motorized ball valve) activates discharging a substantial flow of boiler water. This water is made up with lower conductivity water. Eventually, the bleed stream conductivity will fall to the Set Point value and the controller will shut off the control valve. Select the **Process Cntrl** mode for Continuous Sample method of operation.

3.3.4.3 PROCESS CNTRL.

Choose this mode when your system requires both High and Low process control and for boilers using continuous sampling mode.



For help with menu locations, please refer to the “Menu Map” supplied with your controller.

3.4 Sample Programming

The following is a detailed example of how to program your controller. Once you have mastered this exercise, you will be ready to setup the controller to your specifications.



IMPORTANT! Please note that keypad (soft key) instructions are presented as all capitals in brackets “[ENTER],” items as they appear in the display are presented as all capitals and bold face — “**DISPLAY DATA.**”

For this exercise, you will set “**DAY, WEEK, DATE, and TIME.**”

- At startup, the instrument will eventually display the **HOME** screen. From there, press the [MENU] key until **MAIN MENU** is displayed. Then use the [V] key to move the highlight down to **SYSTEM SETUP.**

Press [ENTER] to display the **SYSTEM SETUP** menu.

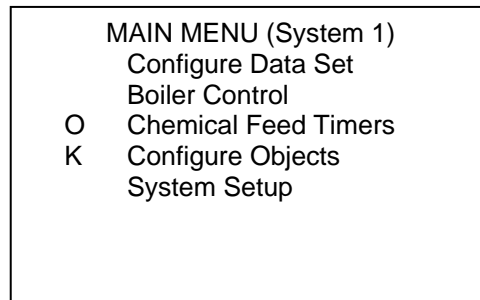

Fig. 15

- Press [^],or [V] to highlight **SET DATE.** Press [ENTER].
- Press the [^],or [V] keys to select the **MONTH.** Press [ENTER]. When the month has been accepted, the curser will move down to the **DATE** number field.
- Use the [^],or [V] keys to select today’s date. Press [ENTER]. When the date has been accepted, the curser will move down to the **YEAR** number field.
- Use the [^],or [V] keys to select the current year. Press [ENTER]. When the year has been accepted, the screen will change to the **SYSTEM SETTINGS** screen.



Be sure to press keys **firmly** until you feel a faint click, then pause before you try again. There is a very slight delay for the controller to react to your command. This is normal.



By time, while programming your controller, you get lost or confused, press the [SHIFT +] keys simultaneously to get back to the **Home Menu** and start again.

4.0 SYSTEM SET-UP

Use this menu to set:

- Sesurity
- Date
- Time
- Date Format
- Time Format
- Language
- Units of Measurement (for your water meters)
- Alarm Relay
- About

To enter this menu, from the **MAIN MENU** press [^],or [V] until **SYSTEM SETUP** is highlighted and press [ENTER] to enter the **SYSTEM SETTINGS MENU**.

4.1 Security

The controller can be configured to have a Security Access Code. When the password system is active, you cannot access the unit without the password. To activate this function, from the **MAIN MENU**, press [^],or [V] until **SETUP** is highlighted and press [ENTER] to select. The **SECURITY MENU** will state that the system is currently **UNLOCKED**, press [ENTER]. The screen will say “Password is required to lock; Enter Password.” Press [ENTER]. Use the [^],[V], [>] or the [SHIFT]+[<] to enter a password using the function keys to select alphanumeric symbols. The password entered should be retained. Your system is now secured. To access the unit, you will be prompted to enter the password, enter the password that you selected. The system is now unlocked. If the current password is known, to change the password press the [^],or [V] **CHANGE PASSWORD** then press [ENTER]. Use the [^],or [V] to highlight **ENTER PASSWORD** then press [ENTER]. Enter the current password then press [ENTER]. Now enter the new password using the function keys to select alphanumeric symbols and press [ENTER]. The new password is now set.

If the controller is locked, and the current password is not known for some reason, a backdoor password can be provided by our Tech Service department. The user would go to the controller and enter into **SECURITY** from the **MAIN MENU**. Use the [^],or [V] to select **CHANGE PASSWORD**. Press [ENTER] and use the [^],or [V] to select **Request Temporary Password**. The controller will provide the user with a password seed. The user would then call our Tech Service department to request a backdoor password. Once issued the user can enter the backdoor password in the field that says “Enter Old Password” and press enter. The user can then cancel security protection or enter a password that they retain.

4.2 Set Date

Press [ENTER] to select. Use the [^],or [V] arrow keys to select the month. Press [ENTER] to accept. The cursor moves down to the **DATE**. Use the function keys to enter today's date, press [ENTER] to accept. The cursor moves down to the **YEAR**. Use the function keys to enter the year. Press [ENTER] to set the date and return to the **SYSTEM SETTINGS MENU**.

4.3 Set Time

Press [ENTER] to select. Use the function keys to enter the time. Then press [ENTER] to accept and return to the **SYSTEM SETTINGS MENU**.

4.4 Set Date Format

Press [ENTER] to select. Then choose one of the following options:

MM/DD/YY
DD/MM/YY
Month Date, Year
Date Month, Year

Use the [^],or [V] arrow keys to select the date format and press [ENTER] to accept and return to the **SYSTEM SETTINGS MENU**.

4.5 Set Time Format

Press [ENTER] to select. Then choose one of the following options:

12 Hr HH:MM:SS
12 Hr HH:MM
24 Hr HH:MM:SS
24 Hr HH:MM

Use the [^],or [V] arrow keys to select the time format and press [ENTER] to accept and return to the **SYSTEM SETTINGS MENU**.

4.6 Set Password

The controller can be configured to have a Security Access Code. When the password system is active, you cannot access the unit without the password. To activate this function, from the **MAIN MENU**, press [^],or [V] until **SETUP** is highlighted and press [ENTER] to select. The **SECURITY MENU** will state that the system is currently **UNLOCKED**, press [ENTER]. The screen will say "The system is unlocked; password is required to lock; enter password." Use the keys to enter the default password 1111 then press [ENTER]. Your system is now secured. To access the unit, you will be prompted to enter the password, enter 1111. To change the password, press [^],or [V] to **Setup** press [ENTER], Press [^],or [V] to **CHANGE PASSWORD** and press [ENTER]. Enter the old password, press [ENTER] now enter the new password using the function keys to select alphanumeric symbols and press [ENTER]. The new password is set.

4.7 Set Language

There are five available languages, English, Spanish, German, Italian, and Chinese. From the **SYSTEM SETTINGS MENU**, when **SET LANGUAGE** is highlighted, press [ENTER] to select. Then use the [^], or [v] arrow keys to select the language and press [ENTER] to accept and return to the **SYSTEM SETTINGS MENU**.

4.8 Units

To change your unit for measuring water, from the **SYSTEM SETTINGS MENU**, press [^], or [v] until the **UNITS** is highlighted and then press CHANGE to toggle between **GALLONS** and **LITERS**.

4.9 Alarm Relay

There are 5 onboard relays and 4 external relays (with optional relay expansion box) available. To change your alarm relay, use the [^] or [v] keys to select. Then press [ENTER] to choose. If you do not want an alarm relay, choose NONE

4.10 About

To determine what software version you currently have, from the **SYSTEM SETTINGS MENU**, arrow Press the [v] key until **ABOUT** is highlighted and press [ENTER] to display the Software information.

5.0 CONTROLLER SET-UP



BEFORE APPLYING POWER, INSURE THAT DEVICES BEING CONTROLLED ARE NOT IN A POSITION TO CAUSE HARM OR DAMAGE IF ACTIVATED UPON INITIAL START-UP.



WHEN POWER IS SUPPLIED TO THE UNIT, LINE VOLTAGE IS PRESENT ON THE I/O BOARD LOCATED IN THE BOTTOM OF THE ENCLOSURE EVEN WITH THE POWER SWITCH OFF.

5.1 GENERAL INFORMATION

The default values for all control features have been factory set, but you will want to fine-tune the controller to meet your specific application.

5.2 CONFIGURE DATA SET

You must configure your controller to match your system, e.g., Cooling Tower or Boiler. From the Home screen, press the [MENU] key to get to the **MAIN MENU**.

HOME SCREEN

09/23/04	8:40:54 AM
System 1	
Cooling Tower	Probe 1
No Flow	No Flow
Invalid	Invalid

Fig. 16

MAIN MENU

	Main Menu System 1
E	View Alarms
N	Configure Data Set
T	Cooling Tower Control
E	Probe 1 Control
R	

Fig. 17

Press the [V] function key until **CONFIGURE DATA SET** is highlighted. Press [ENTER].

DATA SET MENU (SYSTEM 1)

	Data Set Menu (System 1)
E	State: Enabled
N	Name: System 1
T	Control Model: Process Ctrl
E	Flow Monitor: Enabled
R	

Fig. 18



For help with menu locations, please refer to the “Menu Map” supplied with your controller.

5.2.1 State

Press [CHANGE] to **ENABLE** or **DISABLE** the system.

5.2.2 Name

You can rename your system from the standard **SYSTEM 1**. Press [V] key until **NAME** is highlighted and press [ENTER]. Next use the [^],[V] keys and the [>] key to enter alphanumeric characters. Press [ENTER] when finished.

5.2.3 Control Model

Press [^],[V] until the **CONTROL MODEL** is highlighted and press [ENTER] to select your desired mode of operation. Choose one of the optional modes:

COOLING TOWER

BOILER

PROCESS CNTRL.

Then press [ENTER] to select. To further setup your unit, see the following *Set points and Alarms* section.

Flow Detection



It is recommended that a flow switch or auxiliary dry contact from the control panel be used to make the controller outputs inoperative when the system is shut down. This connection is provided for on all controllers. (see Fig.9)

5.2.4 Flow Monitor

Press [CHANGE] to **ENABLE** or **DISABLE** flow detection.

5.2.5 Flow Object

The unit has connections for two “onboard” flow detection devices, one for each system. These are located on the I/O board.

5.2.6 Active Flow State

The flow detector supplied with your unit presents a closed circuit (**ACTIVE CLOSED**) when flow is detected. This is the default setting. If your flow detector is active **OPEN**, you can change the state by pressing [ENTER]. Pressing [CHANGE] continuously toggles between actively OPEN or CLOSED. At this point press [SHIFT] together with [BACK] to return to the **MAIN MENU**.

Set points and Alarms



The Alarm Relay is selected in the **SYSTEM SET UP MENU**, see section 4.9.

5.3 CONTROL MODEL MENU

To set-up Control Points, Set points, Alarms, Timers and Output Relays you will need to enter the **CONTROL MODEL MENU** by pressing [^],or [v] to the mode of operation that you have selected in the **CONFIGURE DATA SET MENU**. Press [ENTER] to select one of the three choices:

5.3.1 COOLING TOWER CONTROL

When you press [ENTER] while this control mode is highlighted, you will enter the **COOLING TOWER MENU (SYS 1)**. Notice that the system is displayed.



Remember that you must make your control mode selection in the **CONFIGURE DATA SET** menu.

Probe One * * * * *



Probe one of this system must be conductivity!!!

5.3.1.1 State

Press [CHANGE] to **ENABLE** or **DISABLE** the current.

5.3.1.2 Conductivity Probe

A list of objects is displayed. You pick the object from the list that you want to use. Probe one on this system must be conductivity.

5.3.1.3 Limit Time

This timer limits the length of time that the Control relay is activated. To set this time press [^],or [v] until the **LIMIT TIMER** is highlighted and press [ENTER] to select. Then use the [^],[v] and [>] keys to enter a time from zero to 23:59:59. and then press [ENTER] to enter the value and return to the **COOLING TOWER MENU**. This is a latched alarm. This alarm can only be cleared by pressing the **CirAlarm** key

5.3.1.4 Control Delay

Occasionally, the probe reading fluctuates above and below the Control Point. This causes a situation called “chattering.” This is when the output relay repeatedly cycles off and on. By programming a Control Delay, you can eliminate this condition. Set this delay time for the

activation of the Control relay that you have selected (see RELAY below). Press [ENTER] to select **CONTROL DELAY** and use the [^],[V] and [>] keys to enter a time from zero to 23:59:59. and then press [ENTER] to enter the value and return to the **COOLING TOWER MENU**.

5.3.1.5 Alarm Delay

Occasionally, the probe reading fluctuates above and below the Alarm setting. This causes a situation called “chattering.” This is when the Alarm Output relay repeatedly cycles off and on. By programming a Alarm Delay, you can eliminate this condition. Set this time to delay the activation of the Alarm relay. Press [ENTER] to select **ALARM DELAY** and use the [^],[V] and [>] keys to enter a time from zero to 23:59:59. and then press [ENTER] to enter the value and return to the **COOLING TOWER MENU**.

5.3.1.6 Set point

A Set point is the desired state of your system. To set this value, press [^],or [V] until the **SET POINT** is highlighted and press [ENTER]. Then use the [^],[V], [>] keys to set the desired value. Then press [ENTER] to return to the **COOLING TOWER MENU**.

5.3.1.7 Relay

You can select which of the four onboard output relays you want to be your conductivity control relay. Arrow Up/Down until the **RELAY** is highlighted and press [ENTER] to enter the **SET RELAY** menu. Then use the [^],or [V] keys to make your selection and then press [ENTER] to select and return to the **COOLING TOWER MENU**. If you have installed an optional Relay Expansion Box, you will have an additional four external relays to select.

5.3.1.8 High Control

The high control point is a setting at which the controller activates an output such as a solenoid “blow down” or “bleed” valve. The Control point value is the offset applied to a Set Point, which is the desired state, to prevent chattering of an output relay (see below). Cooling Towers use a rising set point to keep conductivity at a certain value. The controller activates an output, such as a solenoid "blow down" or "bleed" valve to maintain your system at the Set Point value. Use the [^],[V], [>] keys to set the High Control Point value in μS and press [ENTER] to return to the **COOLING TOWER MENU**. When the system conductivity reaches this value, the output relay will be activated and will remain on until the system conductivity falls to the Set Point value.

5.3.1.9 High Alarm

The High Alarm function will activate the alarm relay output when the conductivity value that you enter into the controller is reached. The Alarm condition will also be displayed in the **ALARM MENU**. Use the [^],[V], [>] keys to set the high alarm set point in micro-Siemens. Then, press [ENTER] to return to the **COOLING TOWER MENU**. The relay will turn off when conductivity falls below this value and the alarm condition will be cleared.

5.3.1.10 High Alarm Email

The High Alarm Email allows the user to select which type of email notification will be sent to the customer. The three types are **Alarm**, **Service**, and **Notify**. This function can be disabled by choosing **Off** in the menu When a High Alarm condition occurs an email will be sent to the selected source. The Alarm condition will also be displayed in the **ALARM MENU**. Use the [^],[V], [>] keys to set the which type of email alarm will be sent. Then, press [ENTER] to return to the **COOLING TOWER MENU**.

5.3.1.11 Limit Time Email

The Limit Email allows the user to select which type of email notification will be sent to the customer. The three types are **Alarm**, **Service**, and **Notify**. This function can be disabled by choosing **Off** in the menu. When a Limit Time Alarm condition occurs an email will be sent to the selected source. The Alarm condition will also be displayed in the **ALARM MENU**. Use the [^],[V], [>] keys to set the which type of email alarm will be sent. Then, press [ENTER] to return to the **COOLING TOWER MENU**

5.3.1.12 Low Alarm

The Low Alarm function will activate the alarm relay output when the Low Alarm value that you enter into the controller is reached. The Alarm condition will also be displayed in the **ALARM MENU**. Use the [^],[V], [>] keys to set the low alarm set point. The relay will turn off when the probe's reading rises above this value and the alarm condition will be cleared. Press [ENTER] to return to the

5.3.1.13 Low Alarm Email

The Low Alarm Email allows the user to select which type of email notification will be sent to the customer. The three types are **Alarm**, **Service**, and **Notify**. This function can be disabled by choosing **Off** in the menu. When a Low Alarm condition occurs an email will be sent to the selected source. The Alarm condition will also be displayed in the **ALARM MENU**. Use the [^],[V], [>] keys to set the which type of email alarm will be sent. Then, press [ENTER] to return to the **COOLING TOWER MENU**

5.3.2 BOILER CONTROL

To configure your process control instrument as a boiler controller, from the **MAIN MENU** arrow Up/Down until the **BOILER CONTROL** is highlighted and press [ENTER].



Remember that you must make your control mode selection in the **CONFIGURE DATA SET** menu.

Probe One



Probe one of this system must be conductivity!!!

5.3.2.1 State

Press [CHANGE] to **ENABLE** or **DISABLE** the current probe.

5.3.2.2 Conductivity Probe

A list of objects is displayed. You pick the object from the list that you want to use. Probe one on this system must be conductivity.



For boilers using the **Continuous Model** sampling method, use the **Process Cntrl. Model** instead of **Boiler Control**.

5.3.2.3 Wait Time (Interval)

The controller will only measure system conductivity when the blow down valve is open. How often the blow down valve is activated is the set by the Wait Time. This is the time

between boiler water samples. To set this time press [^],or [v] until the **WAIT TIME** is highlighted and press [ENTER] to select. Then use the [^],[v] and [>] keys to enter a time from zero to 23:59:59. and then press [ENTER] to enter the value and return to the **BOILER CONTROL MENU**.

5.3.2.4 Sample Time

The unit will only measure system conductivity when the blow down valve is open. The controller opens the blow down valve at the time set above. The length of time the sample valve is open, Sample Time, is set here. However, if the conductivity exceeds the control point, the blow down valve will be held open until the system conductivity is lowered by makeup water. Then the blow down valve will close.

To set this Sample time, press [^],or [v] until the **SAMPLE TIME** is highlighted and press [ENTER] to select. Then use the [^],[v] and [>] keys to enter a time from zero to 23:59:59. and then press [ENTER] to enter the value and return to the **BOILER CONTROL MENU**.

5.3.2.5 Hold Time

The conductivity probe only functions when it is in water. If the sample is steam, the probe will give erroneous conductivity readings. To help solve this situation, the sample can be held for a period of time - Hold Time Mode. This is similar to **SAMPLE TIME** however, after obtaining a sample the blow down valve then closes to hold the water for a period of time before the reading is made. By closing the blowdown valve, the pressure difference across the probe is eliminated and the steam changes to water. If the conductivity exceeds the control point, the blow down valve is opened again and the cycle is repeated until the system's conductivity falls below the control point.

To set this time arrow Up/Down until the **HOLD TIME** is highlighted and press [ENTER] to select. Then use the [^],[v] and [>] keys to enter a time from zero to 23:59:59. and then press [ENTER] to enter the value and return to the **BOILER CONTROL MENU**.

5.3.2.6 Bleed Time

Once a Hold Time is entered, the **BLEED TIME** option appears on the display. Here you will set the amount of time the blow down valve will remain open before the sample is held for a reading. The ideal bleed time for your system depends on many factors and will be determined by trial and error. A good starting point would be to bleed for 10 minutes. To set the **BLEED TIME**, arrow Up/Down until the **BLEED TIME** is highlighted and press [ENTER] to select. Then use the [^], [v] and [>] keys to enter a time from zero to 23:59:59 and then press [ENTER] to enter the value and return to the **BOILER CONTROL MENU**. Then track your conductivity and adjust the time accordingly. If you overshoot your control point, reduce the **BLEED TIME**. If the valve cycles many times per blow down event, increase the **BLEED TIME**.



In this mode, the conductivity is read only at the end of the **HOLD TIME**. If at the end of the **HOLD TIME** the conductivity reading is still above the Control Point, the **BLEED/HOLD** cycle will be repeated until the conductivity falls below the Control Point. Therefore, if the conductivity falls below your Control Point during the **BLEED** cycle, the controller will not recognize this fact until the end of the following **HOLD TIME**.

5.3.3.7 Limit Time

This timer limits the length of time that the Blow down relay is activated. To set this time press [^],or [v] until the **LIMIT TIMER** is highlighted and press [ENTER] to select. Then use the [^],[v] and [>] keys to enter a time from zero to 23:59:59. and then press [ENTER] to enter the value and return to the **BOILER CONTROL MENU**. This is a latched alarm. This alarm can only be cleared by pressing the **ClrAlarm** key

5.3.3.8 Set point

A Set point is the desired state of your system. To set this value, press [^],or [v] until the **SET POINT** is highlighted and press [ENTER]. Then use the [^],[v], [>] keys to set the desired value. To set this value, arrow Up/Down until the **SET POINT** is highlighted and press [ENTER]. Then use the [^],[v], [>] keys to set the desired value. Then press [ENTER] to return to the **BOILER CONTROL MENU**.

5.3.3.9 Relay

You can select which of the four onboard output relays you want to be your conductivity control relay. Arrow Up/Down until the **RELAY** is highlighted and press [ENTER] to enter the **SET RELAY** menu. Then use the [^],or [v] keys to make your selection and then press [ENTER] to select and return to the **BOILER CONTROL MENU**. If you have installed an optional Relay Expansion Box, you will have an additional four external relays to select.

5.3.3.10 High Control

The high control point is a setting at which the controller activates an output such as a solenoid “blow down” or “bleed” valve. The Control point value is the offset applied to a Set Point, which is the desired state, to prevent chattering of an output relay (see below). Boilers use a rising set point to keep conductivity at a certain value. The controller activates an output, such as a solenoid "blow down" or "bleed" valve to maintain your system at the Set Point value. Use the [^],[v], [>] keys to set the High Control Point value in μS and press [ENTER] to return to the **BOILER CONTROL MENU**. When the system conductivity reaches this value, the output relay will be activated and will remain on until the system conductivity falls to the Set Point value. Use the [^],[v], [>] keys to set the value in μS and press [ENTER] to return to the **BOILER CONTROL MENU**.

5.3.3.11 High Alarm

The High Alarm function will activate the alarm relay output when a conductivity value that you enter into the controller is reached. The Alarm condition will also be displayed in the **ALARM MENU**. Use the [^],[v], [>] keys to set the high alarm set point in micro-Siemens. Then, press [ENTER] to return to the **BOILER CONTROL MENU**. The relay will turn off when conductivity falls below this value and the alarm condition will be cleared.

5.3.3.12 High Alarm Email

The High Alarm Email allows the user to select which type of email notification will be sent to the customer. The three types are **Alarm**, **Service**, and **Notify**. This function can be disabled by choosing **Off** in the menu When a High Alarm condition occurs an email will be sent to the selected source. The Alarm condition will also be displayed in the **ALARM MENU**. Use the [^],[v], [>] keys to set the which type of email alarm will be sent. Then, press [ENTER] to return to the **BOILER CONTROL MENU**.

5.3.3.13 Limit Time Email

The Limit Email allows the user to select which type of email notification will be sent to the customer. The three types are **Alarm**, **Service**, and **Notify**. This function can be disabled by choosing **Off** in the menu. When a Limit Time Alarm condition occurs an email will be sent to the selected source. The Alarm condition will also be displayed in the **ALARM MENU**. Use the [^],[V], [>] keys to set the which type of email alarm will be sent. Then, press [ENTER] to return to the **BOILER CONTROL MENU**

5.3.3.14 Low Alarm

The Low Alarm function will activate the alarm relay output when the Low Alarm value that you enter into the controller is reached. The Alarm condition will also be displayed in the **ALARM MENU**. Use the [^],[V], [>] keys to set the low alarm set point. The relay will turn off when the probe's reading rises above this value and the alarm condition will be cleared. Press [ENTER] to return to the

5.3.3.15 Low Alarm Email

The Low Alarm Email allows the user to select which type of email notification will be sent to the customer. The three types are **Alarm**, **Service**, and **Notify**. This function can be disabled by choosing **Off** in the menu. When a Low Alarm condition occurs an email will be sent to the selected source. The Alarm condition will also be displayed in the **ALARM MENU**. Use the [^],[V], [>] keys to set the which type of email alarm will be sent. Then, press [ENTER] to return to the **BOILER CONTROL MENU**

5.3.3 PROCESS CNTRL.

To setup your process control instrument for **PROCESS CNTRL** model, go to the **CONFIGURE DATA SET** screen and press [^],or [V] to **CONTROL MODEL** and press [ENTER]. Press [^],or [V] to **PROCESS CNTRL** and press[ENTER] to select. Press [SHIFT] + [BACK] to return to the **MAIN MENU**



Remember that you must make your control model selection in the **CONFIGURE DATA SET** menu.

TIP

5.3.3.1 PROBE 1 CONTROL (Process Cntrl Mode only)

5.3.3.1.1 State

Press [CHANGE] to **ENABLE** or **DISABLE** the system.

5.3.3.1.2 Probe

A list of objects is displayed. You pick the object from the list that you want to use.

5.3.3.1.3 Set point

A Set point is a setting at which the controller controls a process. **PROBE 1** in Process Cntrl Mode uses both a rising or a falling set point to control your process. To set this value, press [^],or [V] until the **SET POINT** is highlighted and press [ENTER]. Then use the [^],[V], [>] keys to set the desired value. Then press [ENTER] to return to the **PROBE 1 MENU**.

5.3.3.1.4 High Control State

Press [CHANGE] to **ENABLE** a Rising Set Point.



IMPORTANT! Please note that **PROBE 1** can have **HIGH CONTROL** (a Rising Set point) or **LOW CONTROL** (a Falling Set point)

NOTE

5.3.3.1.4.1 High Control

The control point is a setting at which the controller activates an output relay. The Control point value is the offset applied to a Set Point, which is the desired state, to prevent chattering of an output relay (see below). The controller activates an output, such as a pump to maintain your system at the Set Point value. When the probe's reading reaches this value, the output relay will be activated and will remain on until the probe's reading falls to the Set Point value. Use the [^],[V], [>] keys to set the value and press [ENTER] to return to the **PROBE 1 MENU**.

5.3.3.1.4.2 High Alarm

The High Alarm function will activate the alarm relay output when a High Alarm value that you enter into the controller is reached. The Alarm condition will also be displayed in the **ALARM MENU**. Use the [^],[V], [>] keys to set the high alarm set point. The relay will turn off when the probe's reading falls below this value and the alarm condition will be cleared. Press [ENTER] to return to the **PROBE 1 MENU**.

5.3.3.1.4.3 High Alarm Email

The High Alarm Email allows the user to select which type of email notification will be sent to the customer. The three types are **Alarm**, **Service**, and **Notify**. This function can be disabled by choosing **Off** in the menu. When a High Alarm condition occurs an email will be sent to the selected source. The Alarm condition will also be displayed in the **ALARM MENU**. Use the [^],[V], [>] keys to set the which type of email alarm will be sent. Then, press [ENTER] to return to the **PROBE 1 MENU**.

5.3.3.1.4.4 High Relay

You can select which of the four onboard output relays you want to be your High control relay. Arrow Up/Down until the **RELAY** is highlighted and press [ENTER] to enter the **SET RELAY** menu. If you have installed an optional Relay Expansion Box, you will have four external relays to select. Then use the [^] or [V] keys to make your selection and then press [enter] to select and return to **PROBE 1 MENU**.

5.3.3.1.4.5 High Limit Time Email

The High Limit Email allows the user to select which type of email notification will be sent to the customer. The three types are **Alarm**, **Service**, and **Notify**. This function can be disabled by choosing **Off** in the menu. When a High Limit Time Alarm condition occurs an email will be sent to the selected source. The Alarm condition will also be displayed in the **ALARM MENU**. Use the [^],[V], [>] keys to set the which type of email alarm will be sent. Then, press [ENTER] to return to the **PROBE 1 MENU**

5.3.3.1.5 Low Control State

Press [CHANGE] to ENABLE a falling set point.

5.3.3.1.5.1 Low Control

The control point is the offset applied to a set point to prevent chattering of an output relay around a set point. The Low Control point is a setting at which the controller activates an output relay. When the system's falling value reaches this number, the output relay will be activated and will remain on until the system's condition rises to the Set Point value. Use the [^],[V], [>] keys to set the value and press [ENTER] to return to the **PROBE 1 MENU**.

5.3.3.1.5.2 Low Alarm

The Low Alarm function will activate the alarm relay output when the Low Alarm value that you enter into the controller is reached. The Alarm condition will also be displayed in the **ALARM MENU**. Use the [^],[V], [>] keys to set the low alarm set point. The relay will turn off when the probe's reading rises above this value and the alarm condition will be cleared. Press [ENTER] to return to the **PROBE 1 MENU**.

5.3.3.1.5.3 Low Alarm Email

The Low Alarm Email allows the user to select which type of email notification will be sent to the customer. The three types are **Alarm**, **Service**, and **Notify**. This function can be disabled by choosing **Off** in the menu. When a Low Alarm condition occurs an email will be sent to the selected source. The Alarm condition will also be displayed in the **ALARM MENU**. Use the [^],[V], [>] keys to set the which type of email alarm will be sent. Then, press [ENTER] to return to the **PROBE 1 MENU**

5.3.3.1.5.4 Low Relay

You can select which of the four onboard output relays you want to be your Low control relay. Arrow Up/Down until the **RELAY** is highlighted and press [ENTER] to enter the **SET RELAY** menu.

5.3.3.1.5.5 Low Limit Time Email

The Low Limit Email allows the user to select which type of email notification will be sent to the customer. The three types are **Alarm**, **Service**, and **Notify**. This function can be disabled by choosing **Off** in the menu. When a Limit Time Alarm condition occurs an email will be sent to the selected source. The Alarm condition will also be displayed in the **ALARM MENU**. Use the [^],[V], [>] keys to set the which type of email alarm will be sent. Then, press [ENTER] to return to the **PROBE 1 MENU**

5.3.3.1.6 Control Delay

Occasionally, the probe reading fluctuates above and below the Control Point. This causes a situation called “chattering.” This is when the output relay repeatedly cycles off and on. By programming a Control Delay, you can eliminate this problem. Set this delay time for the activation of the Control relay that you have selected (see RELAY below). Press [ENTER] to select **CONTROL DELAY** and use the [^],[V] and [>] keys to enter a time from zero to 23:59:59. and then press [ENTER] to enter the value and return to the **PROBE 1 MENU**.

5.3.3.1.7 Limit Timer

This timer limits the length of time that the Control relay is activated. To set this time press [^],or [V] until the **LIMIT TIMER** is highlighted and press [ENTER] to select. Then use the [^],[V] and [>] keys to enter a time from zero to 23:59:59. and then press [ENTER] to enter the value and return to the **PROBE 1 MENU**.

5.3.3.1.8 Alarm Delay

Occasionally, the probe reading fluctuates above and below the Alarm setting. This causes a situation called “chattering.” This is when the Alarm Output relay repeatedly cycles off and on. By programming a Alarm Delay, you can eliminate this problem. Set this time to delay the activation of the Alarm relay. Press [ENTER] to select **ALARM DELAY** and use the [^],[V] and [>] keys to enter a time from zero to 23:59:59. and then press [ENTER] to enter the value and return to the **PROBE 1 MENU**.

5.4 CLEARING ALARMS

When an Alarm condition is detected, the Alarm LED turns ON and **VIEW ALARMS** is displayed in the **MAIN MENU**.

5.4.1 View Alarms

From the **MAIN MENU**, press [^],or [V] until **VIEW ALARMS** is highlighted and press [ENTER] to select. The **ALARM MENU** will display the following information:

- Alarm Date
- Alarm Time
- The Device
- Reason for Alarm
- 1 of x Alarms (listed)

The Alarm condition will remain until the cause of the alarm is rectified, e.g., a probe value is above the control point. The alarm will remain until the reading goes below the set point, if you have rising set point control.

5.5 CHEMICAL FEED TIMERS

The process control instrument has 3 Selectable Timers that have 5 modes of operation

5.5.1 BLEED AND FEED

This timer is a sub-mode of conductivity monitoring. The **Bleed and Feed** timer starts when conductivity is greater than or equal to the defined control point. The Bleed & Feed Timer has independent Bleed and Feed Timers. The relay will remain activated until the conductivity set point is satisfied or the **Limit Timer** expires.



The **LIMIT TIMER** is set in the **COOLING TOWER** or **BOILER CONTROL MENUS**

5.5.2 PERCENT POST BLEED

– This timer keeps track of the time the bleed relay is turned on. When the bleed shuts off, the timer begins feeding for a percentage of the bleed time. The percentage is adjustable in 1% increments from 0 to 100% of the bleed time.



BLEED AND FEED AND PERCENT POST BLEED are not available in **PROCESS CNTRL MODE**.

5.5.3 PERCENT

Also referred to as a “cycle” timer. The timer runs continuously on an adjustable percentage of the time cycle. The percentage is adjustable from 0 to 100% in 1% increments. The cycle time is adjustable from 0 to 23:59:59.

5.5.4 PULSE MODE

- This timer is commonly referred to as a water meter or reset timer. It monitors pulses accepts pulses from a water meter to activate an output after a pre-set number of pulses.
- Dry contact mode, enter GALLONS/PULSE.
- Hall Effect Mode, enter K factor

5.5.5 28 DAY

Select On/Off each month of the year that the timer will run for a Weekly or Daily schedule.

WEEKLY- Select On/Off each day of week.

Select Every Week, Every 2nd Week, Every 3rd Week, Every 4th Week

DAILY- Every day, every 2 Days, up to every 14 Days

To configure your timer(s): from the **MAIN MENU**, press [^], or [V] until **CHEMICAL FEED TIMERS** is highlighted and press [ENTER]. Use the [^], or [V] arrow keys to select Timer 1, 2 or 3 and press [ENTER] to select.

5.6 Setting the Weekly 28 Day Timer

5.6.1 State

Press [CHANGE] to **ENABLE** or **DISABLE** this timer.

5.6.2 Relay

You can select what relay you wish this timer to control. Press [^],or [V] until **RELAY** is highlighted and press [ENTER] to select.

5.6.3 Type

Press [^],or [V] until **TYPE** is highlighted and press [ENTER] to select, then press [^],or [V] until **28 Day** is highlighted and Press [ENTER] to select.

5.6.4 Schedule

Press [V] until **SCHEDULE** is highlighted and press [ENTER] to choose your schedule. Press [^],or [V] until **WEEKLY** is highlighted and press [ENTER] to make this selection. You will then see the following items on the **TIMER MENU**:

5.6.5 Months: View Edit

Press [ENTER] to enter the **MONTHS SCHEDULE**. Use the function keys to select the month(s), [V] and [>]; [SHIFT] + [<] and [SHIFT] + [^], then use the **ON/OFF** key to turn the timer "on" or "off" for the selected month. Highlighted means ON. Press [ENTER] to accept.

5.6.6 Weeks: View Edit

Press [ENTER] to enter the **WEEKS SCHEDULE**. Use the function keys [V] and [^] to select a schedule of Every Week, Every 2nd Week, Every 3rd Week, Every 4th Week.

5.6.7 Days: View Edit

Press [ENTER] to enter the **28-DAY SCHEDULE**. Use the function keys to select the day(s), [V] and [>]; [SHIFT] + [<] and [SHIFT] + [^], then use the **ON/OFF** key to turn the timer "on" or "off" for the selected day. Press [ENTER] to accept.

5.6.8 Next Run:

Press [ENTER] to enter the **NEXT RUN SCHEDULE**. Use the function keys [V] and [^] to select a schedule of days for the next run to start. For example, if the user is in the plant on Friday, the choices would be Today, Tomorrow, Sunday, Monday, Tuesday, Wednesday and Thursday.

4.6.9 Start Time: View / Edit

There are four independent start times that can be selected for use with any given scheduled day. They all have a common run time. Use the [ENTER] key to enable the start time. Then use the [^],[V] to move to the enabled start time. Press [ENTER] to enter the start time menu. Then use the [V] and [>]; [SHIFT] + [<] and [SHIFT] + [^] enter the start time. Press [ENTER] to accept

5.6.10 Run Time:

Use the [^],[V], [>] and [SHIFT]+ [<] keys to enter the run time. Press [ENTER] to accept.

5.6.11 Lockout Timer:

The Lockout Timer inhibits all system outputs, except the one you choose for this timer, from activating for a certain time period. This is useful if the added chemical requires a retention time in the system. Use the [^],[V], [>] and [SHIFT]+[<] keys to enter the lockout time. Press [ENTER] to accept. Lockout time begins when the run time starts.

5.6.12 Prebleed:

On systems with conductivity, the optional Prebleed phase is useful to assure that the system conductivity is maintained throughout the lockout period. Otherwise, added chemical will be blown down or the system conductivity could rise to levels that could cause scaling. A bleed is forced for a specified period of time in an attempt to bring the system to a minimum conductivity. The bleed relay will be activated until the **PREBLEED POINT** is reached or the **PREBLEED TIMER** expires.

5.6.13 Prebleed Point:

Press [^],or [V] until this is highlighted and press [ENTER] to select. Use the [^],[V], [>] and [SHIFT]+[<] keys to enter the value. Press [ENTER] to accept.

5.6.14 Prebleed Limit Timer:

Press [^],or [V] until this is highlighted and press [ENTER] to select. Use the [^],[V], [>] and [SHIFT]+[<] keys to enter the time. Press [ENTER] to accept. If the **PREBLEED POINT** is not reached before the **PREBLEED LIMIT TIMER** expires, the **ClrAlarm** key is displayed and an Alarm will be displayed in the VIEW ALARMS menu. This alarm will clear after the next complete timer cycle. This alarm can also be cleared by justpressing the **ClrAlarm** key.

5.6.15 Prebleed Limit Email:

The Prebleed Limit Email allows the user to select which type of email notification will be sent to the customer. The three types are **Alarm**, **Service**, and **Notify**. This function can be disabled by choosing **Off** in the menu. When a Prebleed Limit Time Alarm condition occurs an email will be sent to the selected source. The Alarm condition will also be displayed in the **ALARM MENU**. Use the [^],[V], [>] keys to set the which type of email alarm will be sent. Then, press [ENTER] to return to the **28 DAY, WEEKLY MENU**



Prebleed not available in Process Cntrl model.

5.7 Setting the Daily 28 Day Timer

5.7.1 State

Press [CHANGE] to **ENABLE** or **DISABLE** this timer.

5.7.2 Relay

You can select what relay you wish this timer to control. Press [^],or [V] until **RELAY** is highlighted and press [ENTER] to select.

5.7.3 Type

Press [^],or [V] until **TYPE** is highlighted and press [ENTER] to select, then press [^],or [V] until **28 Day** is highlighted and Press [ENTER] to select.

5.7.4 Schedule

Press [V] until **SCHEDULE** is highlighted and press [ENTER] to choose your schedule. Press [^],or [V] until **DAILY** is highlighted and press [ENTER] to make this selection. You will then see the following items on the **TIMER MENU**:

5.7.5 Months: View Edit

Press [ENTER] to enter the **MONTHS SCHEDULE**. Use the function keys to select the month(s), [V] and [>]; [SHIFT] +[<] and [SHIFT] + [^], then use the **ON/OFF** key to turn the timer "on" or "off" for the selected month. Highlighted means ON. Press [ENTER] to accept.

5.7.6 Days: View Edit

Press [ENTER] to enter the **28-DAY SCHEDULE**. Use the function keys to select the day(s), [V] and [>]; [SHIFT] +[<] and [SHIFT] + [^] then use the **ON/OFF** key to turn the timer "on" or "off" for the selected day. Press [ENTER] to accept.

5.7.7 Next Run:

Press [ENTER] to enter the **NEXT RUN SCHEDULE**. Use the function keys [V] and [^] to select a schedule of days for the next run to start. For example, if the user chooses Every Day, the choices would only be Today. However if the user chooses Every Five Days, the choices would be Today, Tomorrow, Sunday, Monday and Tuesday.

5.7.8 Start Time: View/Edit

There are four independent start times that can be selected for use with any given scheduled day. They all have a common run time. Use the [ENTER] key to enable the start time. Then use the [^],[V] to move to the enabled start time. Press [ENTER] to enter the start time menu. Then use the [V] and [>]; [SHIFT] +[<] and [SHIFT] + [^] enter the start time. Press [ENTER] to accept

5.7.9 Run Time:

Use the [^],[V], [>] and [SHIFT]+[<] keys to enter the run time. Press [ENTER] to accept.

5.7.10 Lockout Timer:

The Lockout Timer inhibits all system outputs, except the one you choose for this timer, from activating for a certain time period. This is useful if the added chemical requires a retention time in the system. Use the [^],[V], [>] and [SHIFT]+[<] keys to enter the lockout time. Press [ENTER] to accept. Lockout time begins when the run time starts.

5.7.11 Prebleed:

On systems with conductivity, the optional Prebleed phase is useful to assure that the system conductivity is maintained throughout the lockout period. Otherwise, added chemical will be blown down or the system conductivity could rise to levels that could cause scaling. A bleed is forced for a specified period of time in an attempt to bring the system to a minimum conductivity.

The bleed relay will be activated until the **PREBLEED POINT** is reached or the **PREBLEED TIMER** expires.

5.7.12 Prebleed Point:

Press [^],or [V] until this is highlighted and press [ENTER] to select. Use the [^],[V], [>] and [SHIFT]+[<] keys to enter the value. Press [ENTER] to accept.

5.7.13 Prebleed Limit Timer:

Press [^],or [V] until this is highlighted and press [ENTER] to select. Use the [^],[V], [>] and [SHIFT]+[<] keys to enter the time. Press [ENTER] to accept. If the **PREBLEED POINT** is not reached before the **PREBLEED LIMIT TIMER** expires, the **ClrAlarm** key is displayed and an Alarm will be displayed in the VIEW ALARMS menu. This alarm will clear after the next complete timer cycle. This alarm can also be cleared by justpressing the **ClrAlarm** key.



Prebleed not available in Process Cntrl model.

5.7.14 Prebleed Limit Email

The Prebleed Limit Email allows the user to select which type of email notification will be sent to the customer. The three types are **Alarm**, **Service**, and **Notify**. This function can be disabled by choosing **Off** in the menu. When a Prebleed Limit Time Alarm condition occurs an email will be sent to the selected source. The Alarm condition will also be displayed in the **ALARM MENU**. Use the [^],[V], [>] keys to set the which type of email alarm will be sent. Then, press [ENTER] to return to the **28 DAY, DAILY MENU**

5.8 Setting the Bleed and Feed Timer

5.8.1 State

Press [CHANGE] to **ENABLE** or **DISABLE** this timer.

5.8.2 Relay (Feed)

You can select what (Feed) relay you wish this timer to control. Press [^],or [V] until **RELAY** is highlighted and press [ENTER] to select.

5.8.3 Type

Press [^],or [V] until **TYPE** is highlighted and press [ENTER] to select, then press [^],or [V] until **Bleed and FEED** is highlighted and Press [ENTER] to select.

5.8.4 Limit Timer (Bleed)

From the **MAIN MENU** press [^] or [V] until **COOLING TOWER** or **BOILER** is highlighted and press [ENTER] to select. Next press [^],or [V] to **LIMIT TIMER** and press [ENTER] to select. Use the function keys to enter the limit time up to 23:59:59 and press[ENTER] to save. This is a latched alarm. This alarm can only be cleared by pressing the **ClrAlarm** key

5.9 Setting the Pulse Mode Timer

5.9.1 State

Press [CHANGE] to **ENABLE** or **DISABLE** this timer.

5.9.2 Relay

You can select what relay you wish this timer to control. Press [^],or [V] until **RELAY** is highlighted and press [ENTER] to select.

5.9.3 Type

Press [^],or [V] until **TYPE** is highlighted and press [ENTER] to select, then press [^],or [V] until **Pulse Mode** is highlighted and Press [ENTER] to select. You will then see the following items on the **TIMER MENU**:

5.9.4 Water Meter

Press [^],or [V] until **WATER METER** is highlighted and press [ENTER] to select. There are two onboard inputs. Use the [^],or [V] to the desired selection and then press [ENTER] to select.



NOTE

IMPORTANT! Please note that your Water Meter must be configured in the CONFIGURE OBJECTS MENU.

5.9.5 Pulse Mode Gallons

Press [^],or [V] until **PULSE MODE GALLONS** is highlighted and use the [^],[V], [>] and the [SHIFT]+[<] keys to enter the amount of water to flow through the water meter before turning on your output relay.

5.9.6 Remaining Gallons

Will display the gallons remaining before the next run time occurs. The remaining gallons can be reset to zero at any time independent of the totalized gallons from the water meter. Press [ENTER] to reset the remaining gallons. Use the [^],[V] select Yes to reset the remaining gallons or No if you entered into the menu inadvertently. Press [ENTER] to select and return to the **PULSE TIMER MENU**.

5.9.7 Pulse Mode Time

Press [^],or [V] until **PULSE MODE TIME** is highlighted and use the [^],[V], [>] and the [SHIFT]+[<] keys to enter your time value up to 23:59:59. This sets the time that the output relay is energized when the water value is reached.

5.10 Setting the Percent Post-Bleed Timer

5.10.1 State

Press [CHANGE] to **ENABLE** or **DISABLE** this timer.

5.10.2 Relay

You can select what relay you wish this timer to control. Press [^],or [V] until **RELAY** is highlighted and press [ENTER] to select.

5.10.3 Type

Press [^],or [V] until **TYPE** is highlighted and press [ENTER] to select, then press [^],or [V] until **% Post Bleed** is highlighted and Press [ENTER] to select. You will then see the following items on the **TIMER MENU**:

5.10.4 % Post Bleed:

Press [^],or [V] until **% POST BLEED** is highlighted and use the [^],[V], [>] and the [SHIFT]+[<] keys to enter your percent value from 0 to 100%.

5.10.5 Limit Time:

Press [^],or [V] until this is highlighted and press [ENTER] to select. Use the [^],[V], [>] and [SHIFT]+[<] keys to enter the time limit. Press [ENTER] to accept. This is a latched alarm. This alarm can only be cleared by pressing the **ClrAlarm** key

5.11 Setting the Percent Timer

5.11.1 State

Press [CHANGE] to **ENABLE** or **DISABLE** this timer.

5.11.2 Relay

You can select what relay you wish this timer to control. Press [^],or [V] until **RELAY** is highlighted and press [ENTER] to select.

5.11.3 Type

Press [^],or [V] until **TYPE** is highlighted and press [ENTER] to select, then press [^],or [V] until **Percent** is highlighted and Press [ENTER] to select. You will then see the following items on the **TIMER MENU**:

5.11.4 Cycle Time:

Press [^],or [V] until **CYCLE TIME** is highlighted and press [ENTER] to select. Use the [^],[V], [>] and [SHIFT]+[<] keys to enter the cycle time up to 23:59:59. Press [ENTER] to accept.

5.11.5 Cycle %:

Set the percentage of the Time Cycle here by press [^],or [V] until **CYCLE %** is highlighted and press [ENTER]. Use the [^],[V], [>] and [SHIFT]+[<] keys to enter the desired percentage from 0 to 100%.

6.0 SYSTEM CALIBRATION

6.1 Introduction

Calibration adjusts the reading on your controller to some known standard -- be it a hand held meter or a standard solution sample. A number of different calibration techniques are offered on this controller. Some techniques are more sophisticated and time consuming than others. You should choose the technique that best fits your requirements. To make controller calibration easier, all of the calibration menus loENTER the same. For example, once you know how to calibrate **System Conductivity**, you can use the same technique (and comparable menus) to calibrate **pH**.

6.2 Calibration: Q & A

6.2.1 What does calibration do?

Probe calibration adjusts the reading on your process control instrument to some known standard – be it a hand held meter using a sample from your system or a standard solution sample. The process control instrument’s probes can be calibrated using either the standard method or it can be done remotely using the optional *IntelliScan* wireless hand held calibrator. So, when you put your pH probe in 10pH buffer, the unit displays a value of 10pH.

6.2.2 How do you calibrate?

To calibrate an object, place the probe in a known solution, allow the reading to stabilize (usually 30 seconds), then enter the value into the program through the front panel. Depending on the type of calibration you are doing, you may repeat the process for a second solution or reading.

6.2.3 How does calibration work?

To display a value like conductivity, the controller converts a “Raw” reading into a scaled reading. An equation is used to perform this scaling. At the end of the calibration process, the constant values used in this equation are calculated. A minimum of two calibration points are required. You can either enter both points (**2-Point Calibration**) or enter one point (**1-Point Calibration**) and have the controller assume the second point.

6.3 Configure Object

All calibration is done in this menu. From the **MAIN MENU**, press [^],or [V] until **CONFIGURE OBJECT** is highlighted and press [ENTER] to select.

From the **CONFIGURE OBJECT MENU**, press [^],or [V] to select the probe that you want to calibrate using [ENTER] to select. After the object is selected, the **SELECT OBJECT FUNCTION** menu displays the following:

- Configure
- 1-Point Calibration
- 2-Point Calibration
- About

6.3.1 Renaming the Object

The object to be calibrated can be renamed. From the **OBJECT MENU** press [^],or [V] until **CONFIGURE** is highlighted and press [ENTER] to select. Press [^],or [V] until **NAME** is highlighted and press [ENTER] to select. Then use the [?],[?], {>} and the [Shift]+[DEL] keys to enter alphanumeric characters. Then press [ENTER] to save the new name.

6.4 Calibrating Probes

Next chose 1–Point or 2–Point calibration using the [^],or [V], [ENTER] keys to select. An initial 2- Point calibration is recommended. After a 2-Point calibration is performed, a 1-Point calibration can “fine-tune” your readings. Let us select a 2-Point first.

6.4.1 1-Point Calibration

In a **1-Point Calibration**, you need one solution with a known value. You place the probe in the solution, wait for the signal to stabilize (usually 30 seconds), then enter the value. The second point is assumed by the controller by setting the “Raw” zero to the input zero. This type calibration only adjusts the offset of the probe.

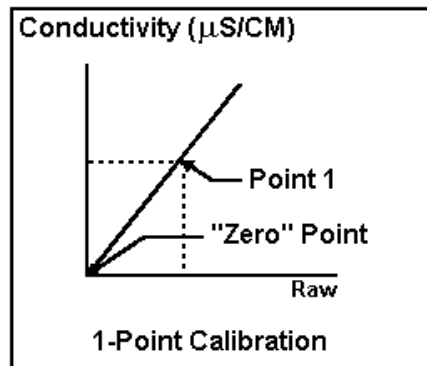

Fig. 19

1 Point Calibration:

- Remove the probe/IntelliSense assembly from the system
- Place the probe into a known solution. The value of this solution coming from a standard or from a hand held meter will be displayed on the screen.
- This will be displayed as the last reading.
- When a reading is stable on the controller display, 1000uS for example, press [ENTER].
- Enter the actual solution value by using the [^],[V], [>] or the [SHIFT]+[<] keys.
- Press [ENTER] calibration for this probe is complete. Unit will display “Calibration Complete”.
- Press [Shift+Home] to return to the Home Menu.
- Replace the probe and repeat this process for each probe in your system 5.3.2.2-Point Calibration

6.4.2 2-Point Calibration

In a **2-Point Calibration**, you need two solutions with known values. You place the probe in one solution, wait for the signal to stabilize, then enter the value. You then rinse the probe and move it to the second solution, wait for the reading to stabilize (usually 30 seconds) then enter the second value. This type of calibration adjusts both slope and offset of the probe.

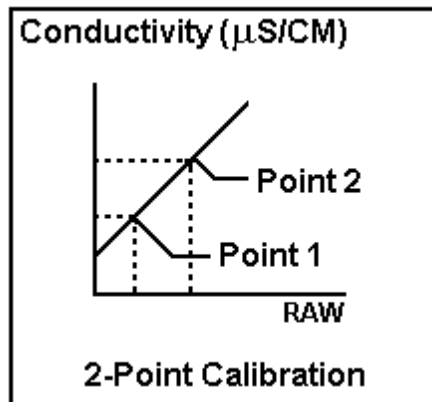

Fig. 20



INITIALLY, ALL PROBES SHOULD BE CALIBRATED USING THE TWO POINT METHOD.

NOTE

2 Point Calibration:

- Remove the probe/IntelliSense assembly from the system
- You will need two known solutions or you can use “air” for the low (zero) value, i.e. conductivity.
- Place the probe into the first solution. The value of this solution coming from a standard or from a hand held meter will be displayed on the screen. Enter this first value.
- When a reading is stable on the controller display, 500µS for example, press **[ENTER]**.
- This will be displayed as the last reading.
- Enter the actual solution value by using the [^],[V], [>] or the [SHIFT]+[<] keys.
- Press **[ENTER]** calibration for point 1 is complete.
- Rinse the probe.
- Place the probe into the second solution. The value of this solution coming from a standard or from a hand held meter will be displayed on the screen.
- When a reading is stable on the display, 5000uS for example, press **[ENTER]**.
- Enter the actual solution value by using the [^],[V], [>] or the [SHIFT]+[<] keys.
- Press **[ENTER]** calibration for point 2 is complete. Unit will display “Calibration Complete”.
- Press [Shift+Home] to return to the Home Menu.
- Replace the probe and repeat this process for each probe in your system

6.5 Boiler Calibration Notes

Boilers probes should be calibrated using 2-point calibration initially, usually using “air” for the low (zero) reading. After an initial 2-Point calibration, boiler probes are usually calibrated using the following 1-Point method and the probe is not removed.

- Water samples are obtained from the blow down (bleed) line using the HOA relay control key on the front panel.
- Press the Bleed relay key once to open the valve. After you have attained a sample, press the key again to close the valve.



NOTE

It is recommended that the blow down valve remains open long enough to completely flush out the blow down line. The result of this will be a more accurate conductivity value used for calibration. This procedure will optimize the control of your boiler system.

CAUTION: If you are using a standard hand held tester, remember to cool the sample to 158°F (70°C) before proceeding with calibration.

- From the **Object Menu** select the probe that you want to calibrate using **[ENTER]** to select. Next chose 1–Point or 2–Point calibration using the
- **[UP]**, **[DOWN]**, **[ENTER]** keys to select. Select 1-Point.
- Enter the actual solution value obtain from your handheld tester by using the ^, V, ► keys.
- Press **[ENTER]** calibration for this probe is complete.
- Repeat this process for each probe in your system.

6.6 Conductivity Function Calibration Notes



Whenever possible, calibrate one or more points on system water with flow turned on.



The performance of conductivity probes can be affected by oil from your skin. Do not touch the metal surfaces at the probes tip.

6.7 pH Function Calibration Notes

- The most common buffers are 4, 7 and 10. Any pH buffer will work if there is at least 3 pH units difference between solutions.
- If **2 Point Calibration** is used, always use two buffers that are most representative of the operating conditions. For example: if monitoring around 8 pH, use a 7 buffer for the low point and 10 for the high point; if monitoring around 6 pH, use a 4 buffer for the low and 7 for the high.
- Between each sample, rinse the probe with De-ionized Water



BE CAREFUL WHEN REMOVING PROTECTIVE LIQUID FILLED BOOT OR BOTTLE FROM PROBE TIP. FOR BOTTLE TYPE, TWIST BOTTLE OFF CAP THEN PULL CAP OFF TIP.

6.8 ORP Function Calibration Notes

The most common mV solutions are 100 and 465. Any mV calibration solution will work. Between each sample, rinse the probe with De-ionized Water.



NEVER EXPOSE PROBE TIP TO THE AIR FOR MORE THAN 45 SECONDS.

6.9 MPIO (Multipurpose Input/Output Intellisense)

The orange MPIO *IntelliSense* is used for **4-20mA input** and **output** signals, it can also supply **24 VDC** power to your output or input device. It can be used for a dry relay input, i.e. **water meter input (dry contact or hall effect)** and a **dry relay output**. The table below shows wiring connections that are made to the terminal block inside the *IntelliSense* Adapter (see Fig.21). Run the wire from your I/O device through the liquid tight connector located on the bottom of the *IntelliSense Adapter*. Strip the wires and connect them to the terminal block using the chart below

Terminal 1	4-20 mA Output (+)
Terminal 2	4-20 mA Output (-)
Terminal 3	4-20 mA Input (+)
Terminal 4	4-20 mA Input (-)
Terminal 5	+5 VDC (50 mA Max.)
Terminal 6	Hall Effect /Dry Contact In
Terminal 7	Dry Contact Out (+)
Terminal 8	Dry Contact Out (-)
Terminal 9	Ground

Fig. 21

6.9.1 Configuring Your MPIO Intellisense

From the **MAIN MENU**, press [^],or [V] until the **CONFIGURE OBJECTS** menu is highlighted and press [ENTER] to select. Then press [^],or [V] until **MPIO Hat** is highlighted and press [ENTER] to select. Use the function keys to highlight **CONFIGURE** and press [ENTER] to enter the **CONFIGURE OBJECTS MENU**.

6.9.1.1 Name:

You can rename your Intellisense from the standard MPIO Hat. In the **CONFIGURE OBJECTS MENU**, Press [V] until **NAME** is highlighted and press [ENTER]. Next use the [^],or [V] and the > key to enter alphanumeric characters. Press [ENTER] when finished.

6.9.1.2 Service (See Maintenance Section)

6.9.1.3 Water Input:

Press [CHANGE] to select between **DRY CONTACT** or **HALL EFFECT**

6.9.1.3.1 Dry Contact

With a Dry Contact water meter, you must set how many gallons or liters/pulse.



The unit of measure (gallons or liters) must be selected in the **SYSTEM SETUP** menu.

6.9.1.3.1.1 Gallons/Pulse

Press [^],or [V] until the **Gallons/Pulse** is highlighted and press [ENTER] to select. Use the input keys to enter the number specified on your meter and press [ENTER] to accept.

Or:

6.9.1.3.2.. Hall Effect

With a Hall Effect water meter, you must enter the "K" factor.

6.9.1.3.2.1 K-Factor

Press [^],or [V] until **K-FACTOR** is highlighted, then press [ENTER] to select. Then use the function keys to enter your K-factor, and press [ENTER] to accept.

6.9.2 Reset

Pressing [ENTER] will reset the count to zero

6.9.3 (4-20)mA Input Setup and Calibration

Wire your 4-20mA input devices to the MPIO terminal block using the above wiring instructions

From the **MAIN MENU**, use the function keys to highlight the **CONFIGURE OBJECTS MENU**, and press [ENTER] to select. Next, use the function keys to highlight MPIO HAT and press [ENTER] to select. Next select **CONFIGURE** and press [ENTER]. Use the function keys to select:

6.9.3.1 4-20 In Type:

Press [ENTER] to enter the **4-20 INPUT MENU** and you will see the following optional objects:

- pH
- ORP
- Cond 2 Wire
- Cond Toroidal
- CIO2
- Free Cl
- Ca Hardness
- Total Hardness
- Other (see notes below)

Press [^],or [V] until your device is highlighted and press [ENTER] to select. Use the same procedure for each 4-20 type.

6.9.3.2 4-20 In Scale: View / Edit

This is where you will calibrate your input signal. From the **CONFIGURE OBJECT MENU**, press [^],or [V] until **IN SCALE: VIEW/EDIT** is highlighted and Press [ENTER] to select

6.9.3.2.1 Low Current

To calibrate your device, first you will enter the **LOW CURRENT** value. When **LOW CURRENT** is highlighted, press [ENTER] to select. Next use the function keys to enter the Low Current Value, e.g., for 4 mA., enter 04.00 and press [ENTER] to save.

6.9.3.2.2 Low Value

Next, you will enter what pH value this current equals. When the **LOW VALUE** is highlighted, press [ENTER] to select. Then use the function keys to enter your Low pH Value, e.g., if 4 mA. equals 4 pH, enter 04.00 and press [ENTER] to save.



NOTE

The unit value will change depending on the object type, e.g. for ORP the value will be in "millivolts", for Conductivity it will be micro-siemens, etc. But for object type "Other", no units are displayed. However, By changing the name of the "Other" object, in the **CONFIGURE OBJECTS MENU**, you can manually enter your unit of measure. For example, if you are measuring degrees Celsius, change the name to, "Temp C." This changed name, i.e., unit of measure, will now appear instead of Cooling Tower/Boiler/Probe 1 or 2 on the **HOME MENU** screen depending on your mode of operation.

6.9.3.2.3 High Current

Next, you will enter your **HIGH CURRENT** value. When **HIGH CURRENT** is highlighted, press [ENTER] to select. Next use the function keys to enter the High Current Value, e.g., for 20mA, enter 20.00 and press [ENTER] to save.

6.9.3.2.4 High Value

Next, you will enter what pH value this current equals. When the **HIGH VALUE** is highlighted, press [ENTER] to select. Then use the function keys to enter your High pH Value, e.g., if 20mA equals 14 pH, enter 14.00 and press [ENTER] to save

6.9.3.2.5 4-20 In Power: On / Off

The MPIO Hat can also supply 24 VDC power to your input device (see the wiring chart). To turn this feature On, press [^],or [V] until the **IN POWER** is highlighted and press [CHANGE] to toggle between On and Off.

6.9.4 4-20mA Output Setup and Calibration

The 4-20mA Output function of the MPIO is primarily for use with Energy Management Systems or chart recorders. You can select any object on your system (network) to control this signal. From the **MAIN MENU**, press [^],or [V] to **CONFIGURE OBJECTS** and press [ENTER] to select. Press [^],or [V] to **MPIO** and press [ENTER] to select. When **CONFIGURE** is highlighted, press [ENTER] to select.

6.9.4.1 4-20 Out Src(source):

From the **CONFIGURE OBJECT MENU**, press [^],or [V] until **4-20 OUT SCR** is highlighted and Press [ENTER] to select. The objects on your system will be displayed. Press [^],or [V] until the object that you want to output the 4-20 mA signal, and press [ENTER] to select.

6.9.4.2 4-20 Out Scale: View / Edit

This is where you will calibrate your output signal. From the **CONFIGURE OBJECT MENU**, press [^],or [V] until **OUT SCALE: VIEW/EDIT** is highlighted and Press [ENTER] to select.

6.9.4.2.1 Low Current

To calibrate your device, first you will enter the **LOW CURRENT** value. When **LOW CURRENT** is highlighted, press [ENTER] to select. Next use the function keys to enter the Low Current Value, e.g., for 4 mA., enter 04.00 and press [ENTER] to save.

6.9.4.2.2 Low Value

Next, you will enter what pH value this current equals. When the **LOW VALUE** is highlighted, press [ENTER] to select. Then use the function keys to enter your Low pH Value, e.g., if 4 mA. equals 4 pH, enter 04.00 and press [ENTER] to save.



NOTE

4-20mA outputs maintain their readings even with loss of flow. Be aware that the reading may not represent the condition of the system - chemical backup, air bound probes etc. can cause inaccurate readings when the flow is off.

6.9.4.2.3 High Current

Next you will enter your **HIGH CURRENT** value. When **HIGH CURRENT** is highlighted, press [ENTER] to select. Next use the function keys to enter the High Current Value, e.g., for 20mA, enter 20.00 and press [ENTER] to save.

6.9.4.2.4 High Value

Next, you will enter what pH value this current equals. When the **HIGH VALUE** is highlighted, press [ENTER] to select. Then use the function keys to enter your High pH Value, e.g., if 20mA equals 14 pH, enter 14.00 and press [ENTER] to save

6.9.4.2.5 4-20 Out Power: On / Off

The MPIO Hat can also supply 24 VDC power to your output device (see the wiring chart). To turn this feature On, press [^],or [V] until the **IN POWER** is highlighted and press [CHANGE] to toggle between **ON** and **OFF**.

6.10 Water Meters (Onboard)

To setup your water meter(s), that you have wired to your controller, go to the **CONFIGURE OBJECTS MENU** press [^],or [v] until **ONBOARD WATER METER 1 or 2** is highlighted and press [ENTER] to enter the **ONBOARD WATER METER MENU**.

6.10.1 Water Input:

Press [CHANGE] to select between **DRY CONTACT** or **HALL EFFECT**

6.10.1.1 Dry Contact

With a Dry Contact water meter, you must set how many gallons or liters/pulse.



The unit of measure (gallons or liters) must be selected in the **SYSTEM SETUP** menu.

6.10.1.1.1..Gallons/Pulse

Press [^],or [v] until the **Gallons/Pulse** is highlighted and press [ENTER] to select. Use the input keys to enter the number specified on your meter and press [ENTER] to accept

6.10.1.2 Hall Effect

With a Hall Effect water meter, you must enter the meter's "K" factor.

6.10.1.2.1 K-Factor

Press [^],or [v] until **K-FACTOR** is highlighted, then press [ENTER] to select. Then use the function keys to enter your K-factor. Then press [ENTER] to enter this value.

6.10.2 Reset

Pressing [ENTER] will reset the count to zero



This information (K-factor) is obtained from the water meter's documentation.

7.0 MAINTENANCE

The only maintenance required on your controller is periodic cleaning and calibration of the probes. It is recommended that you establish a regular maintenance schedule designed to meet the needs of your particular application. All other service should be performed by factory authorized personnel only. Modifications to or tampering with the circuit level components makes all warranties, written or implied, and/or manufacturer's responsibility for this controller null and void.

7.1 Service Schedule Setup

Your process control instrument can be setup to notify you when to perform routine maintenance on your probes. This is setup in the **CONFIGURE OBJECTS MENU**. To setup a service program, from the **MAIN MENU**, arrow Up/Down until **CONFIGURE OBJECTS** is highlighted and press [ENTER] to select. From the **OBJECTS MENU**, arrow Up/Down until the probe you want to setup is highlighted and press [ENTER] to select. Next arrow Up/Down until **CONFIGURE** is highlighted and press [ENTER] to select.

7.1.1 Service Alarm:

Arrow Up/Down until **SERVICE ALARM** is highlighted and press [CHANGE] to toggle between enable or disable. Choose **ENABLE** if you want to use this feature.

7.1.2 Service Days:

Arrow Up/Down until **SERVICE DAYS** is highlighted and press [ENTER] to select. Use the function keys to enter the service period from 90 to 1 and press [ENTER] to save this value and return to the **CONFIGURE OBJECTS MENU**.

7.1.3 Last Service:

This displays the date that the probe was last serviced. To enter this date, from the **CONFIGURE OBJECTS MENU** arrow Up/Down until **LAST SERVICE** is highlighted and press [ENTER] to select.

7.1.4 Next Service:

This displays next service date based on the number of service days selected above.

7.2 Service Alarm Reset

When the service time is reached, the Service LED will illuminate on the IntelliSense and on the controller. This will notify you that it is time to service your probe. **VIEW SERVICE** will now appear on the **MAIN MENU**. This is where you will see what probe(s) need service.

7.2.1 View Service

To reset the Service Alarm, from the **MAIN MENU**, arrow Up/Down until **VIEW SERVICE** is highlighted. Press [ENTER]. The probe(s) scheduled for service appears here. When you press [ENTER], the selected probe's Service Interval will be Reset and the date of Last Service will be updated. The Service LED on the Intellisense will go Off, and if this is the only probe that was

scheduled for service, the Service LED on the controller will also go off. However, if there is more than one probe past scheduled service time, the LED on the controller will remain on until all of the probes have been reset.



To reset your **SERVICE DAYS**, you must go to the **CONFIGURE OBJECTS MENU** (see above).

7.3 Conductivity Probe removal and cleaning

7.3.1 To remove a conductivity probe from its tee for cleaning:

- Remove power to the system.
- Remove pressure from the system prior to unscrewing the probe by closing the hand valves located before and after flow assembly.
- Open the sample port; this will facilitate removal of probe.
- Unscrew the coupling nut.
- Remove the probe by pulling it away from the pipe tee. If necessary, assure slot on nut and tabs on probe or probe holder are NOT lined up (see cleaning instructions below).

7.3.2 To re-install a conductivity probe:

- Reinsert the probe (some conductivity probes are keyed).
- Hand tighten nut.
- Close sample port.
- Reapply pressure and flow by opening hand valves slowly to avoid water hammer.
- Reapply power to the system.

7.3.3 To clean a Stainless Steel conductivity probe:

- Wipe the probes with a clean cloth.
- Use a fine grain emery cloth for stubborn stains.
- Some fouled probes might require dipping in a mild solution of muriatic acid in order to remove fouling.



USE PROPER HANDLING PROCEDURES INCLUDING RUBBER GLOVES, EYE PROTECTION AND PROTECTIVE CLOTHING, WHEN HANDLING ANY ACID SOLUTION.

- Oils can affect probe performance. Do not touch probe surface. The probe can be agitated in a mild solution of dishwashing soap and water to remove oils transferred during handling.

7.4 Boiler Probe Removal and Replacement

To remove a boiler probe from the skimmer blow down line for cleaning and for reinstallation, keep the following in mind:

- Remove power from the system.
- Remove pressure from the system before unscrewing the probe; to remove pressure, close the isolation valve before the probe.
- Open the flush valve to drain water from the probe. This will facilitate removal of the probe.
- Remove the probe by screwing it counter-clockwise.
- Reinstalling the probe by screwing it clockwise, paying attention to the direction of flow. The probe flats should be perpendicular to the flow direction, i.e., the flow should pass between the electrodes.

7.5 Boiler Probe Cleaning

- Wipe the electrodes with a clean cloth.
- Use a fine grain emery cloth for stubborn stains.
- Oils can affect probe performance. Do not touch electrode surfaces. The probe can be agitated in a mild solution of dishwashing soap and water to remove oils transferred during handling.
- Some fouled electrodes might require dipping in a mild solution of muriatic acid in order to remove fouling.

7.6 pH probe Information

The combination pH probe supplied with your controller is designed for maximum reliability, accuracy, and ease of use. The reference half-cell is sealed and non-refillable. The probe is shipped with a protective boot or bottle filled with a junction wetting agent.

7.6.1 Preparation

Remove the lower portion of the protective boot and rinse the probe tip with tap water. It is possible that air bubbles may have migrated into the pH sensitive bulb during shipment. The probe is unable to function with air in the bulb. To remove air, gently shake the probe downward in the same manner as a clinical thermometer. Prior to first usage or after long-term storage, immerse the lower end of the probe in tap water for thirty minutes. This hydrates the pH bulb and prepares the liquid junction for contact with the test solution.

Occasionally during long-term storage or shipment, the probe may develop a film on the pH bulb. The film may be removed by following probe cleaning instructions.

7.6.2 Probe Storage

To maintain response, probes should always remain wet. The preferred storage solution is pH 4.0 buffer with saturated KCl added. Tap water will suffice for short-term storage.



Do not soak in distilled water. The supplied storage boot or bottle will provide an ideal chamber for lengthy storage.

7.6.3 Probe Cleaning

Probes, which are mechanically intact, can often be restored to full response by the following procedures:

- Inorganic Scale Deposits. Dissolve the deposit by immersing the probe first in 0.1M HCl (hydrochloric acid), then in 0.1M NaOH (sodium hydroxide), and again in 0.1M HCl. Each immersion should be for a 5-minute period.
- Organic Oil or Grease Films. Wash probe tip in a liquid detergent and water. If film is known to be soluble in a particular organic solvent, wash with this solvent. Rinse probe tip in tap water.
- If these procedures fail to rejuvenate the probe, the problem is most likely a clogged liquid

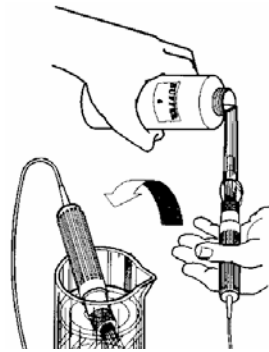

Fig. 22

- junction. Cleaning the liquid junction involves heating a diluted KCl (Potassium Chloride) solution to 60-80°C (139-176°F). Place probe tip in the heated KCl solution for approximately ten minutes. Allow the probe to cool while immersed in the solution before re-testing. If these steps fail to improve the probe response, replace the probe.

7.7 ORP Probe Information

The ORP option provides monitoring and control with a control point in millivolts (mV).

7.7.1 ORP Maintenance and Troubleshooting

ORP standard buffers of 100mV and 465mV are readily available, making it easy to standardize ORP systems against buffers. Like pH probes, ORP probes are subjected to coating and abrasion by the measured liquid and, in certain instances, are “poisoned” by chemicals that may be present if the system goes out of control. To improve the reliability of ORP measurement and control,

the following is a means of testing probes in solutions of standard potential, which will determine if probes are responding correctly or need maintenance attention.

7.7.2 Testing ORP Probe

Solution A: Use sufficient 100mV buffer to immerse probes. Potential should be within +/- 10.

Solution B: Remove probes and rinse thoroughly with water. Immerse probes in 465mV solution. There should be a rapid response.

The millivolt difference between the two solutions is theoretically 365mV. The absolute values may shift upward or downward a few millivolts due to slight variations from theoretical potential by the reference probe.

If system potentials are correct, flush probes with deionized water and measure the liquid in question. If incorrect by more than 10 mV, probes should be cleaned with aqua regia (three volumes hydrochloric acid, one volume concentrated nitric acid.) Repeat above tests. Once satisfactory readings are obtained, install probes and make measurements of liquid in question.



USE PROPER HANDLING PROCEDURES INCLUDING RUBBER GLOVES, EYE PROTECTION AND PROTECTIVE CLOTHING, WHEN HANDLING ANY ACID SOLUTION.

7.8 Flow Switch

The **Flow Switch** uses differential pressure to cause a shuttle to rise and magnetically activate a reed switch. Occasionally this assembly may become fouled, preventing the shuttle from rising and/or falling.

- To clean the assembly:
- Close isolation valves and relieve system pressure from the flow assembly.
- Remove flow cap by loosening retaining nut. Remove flow cap from flow body by pulling straight out.
- Remove red shuttle by pulling straight out. Note post shuttle rides on.
- Clean all internal surfaces of flow body with soft bristle bottle brush. Be careful of the post that the shuttle rides on, its surfaces must be clean, but do not break it while cleaning.
- Clean shuttle exterior surfaces and shuttle bore with a soft brush. You may use a mild dish soap if desired. Flush well before re-installing.
- Re-install shuttle and attach flow cap. Open isolation valves. Check for leaks.

8.0 FACTORY INITIALIZE

You can re-initialize your controller to its factory settings.

- Remove power.
- Hold down the Left and Right Soft Keys and apply power.

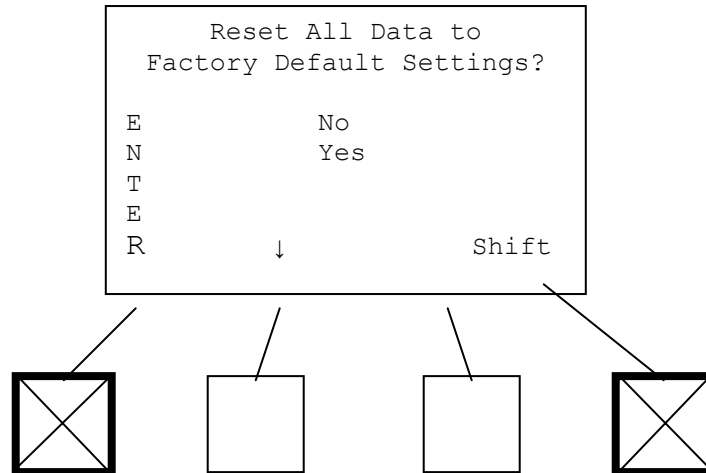

- Select No or Yes by using the Up/Down keys.

Fig. 23



WARNING

WHEN INITIALIZING OR RE-INITIALIZING YOUR CONTROLLER, ALL OF THE SYSTEM SETTINGS WILL BE OVERWRITTEN BY ORIGINAL FACTORY DEFAULT SETTINGS. THE CONTROLLER MUST BE RECONFIGURED TO YOUR SPECIFICATIONS.

- A warning screen is displayed informing you that all existing setup data will be overwritten and asking if you are sure that you want to proceed - no or yes.
- Press [YES] to continue the Initialization, press [NO] to abort. If you continue with initialization, the display will blank and the system will re-start.
- If you aborted the Initialization, the **HOME** menu is displayed.

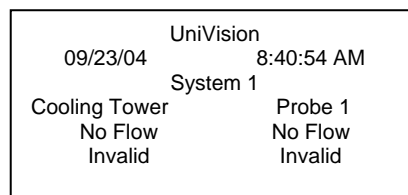

Fig. 24

9.0 FACTORY DEFAULT VALUES



Your controller may not include all of these features

SYSTEM 1	DEFAULT
CONFIGURE DATA SET	
State	Disabled
Name	System 1
Control Model	Boiler
Flow Monitor	Disabled
Flow Obj.	Onboard 1
Active Flow State	Closed
No Flow Email	Off
BOILER CONTROL	
State	Disabled
Cond. Probe	
Wait Time	00:00:00
Sample Time	00:00:00
Hold Time	00:00:00
Bleed Time (if Hold function is activated)	00:00:00
Limit Time	00:00:00
Set Point	0 μ S
Relay	Onboard 1
High Control	0 μ S
High Alarm	0 μ S
High Alarm Email	Off
Limit Time Email	Off
Low Alarm	0 μ S
Low Alarm Email	Off
CHEMICAL FEED TIMERS	
Timer 1	Disabled
Timer 2	Disabled
Timer 3	Disabled
CONFIGURE OBJECTS	
MPIO (If connected)	MPIO Hat
Configure	
Name	MPIO Hat
Service Alarm	Disabled
Service Days	90
Last Service	00/00/00
Next Service	00/00/00

Water Input	Hall Effect
K-Factor	4.000
Reset	0 Gallons
4-20 In-Type	ClO2
4-20 In-Scale	View/Edit
Low Current	0.00
Low Value	0.00
High Current	0.00
High Value	0.00
4-20 In Power	Off
4-20 Out Src	
4-20 Out Scale	
Low Current	4.00
Low Value	0.00
High Current	20.00
High Value	0.00
4-20 Out Power	Off
Onboard	Water Meter 1
Water Input	Dry Contact
Gallons/Pulse	0.000
Reset	0 Gallons
Conductivity(If connected)	Cond 2- Wire
Configure	
Name	CondHat 1
Service Alarm	Disabled
Service Days	90
Last Service	00/00/00
Next Service	00/00/00
pH,ORP,Toroidal(If connected)	Same as Conductivity
 SYSTEM SETUP	
Security	
Lockout State	Unlocked
Change Password	
Set Date	
Month	January
Date	1
Year	2000
Set Time	
Set Date Format	
Set Time Format	
Set Language	
Units	Gallons
About	

10.0 TROUBLE SHOOTING GUIDE

If your controller is not operating properly, proceed through the troubleshooting instructions

SYMPTOM	POSSIBLE CAUSE(S)	POSSIBLE SOLUTION
No Power Light on controller.	<ol style="list-style-type: none"> 1. Power switch off. 2. No power supplied. 3. Blown fuse. 4. Interconnecting cable loose. 5. Power Supply Defective 	<ol style="list-style-type: none"> 1. Turn power switch on 2. Check power source 3. Replace fuse on power supply or main fuse on I.O. board 4. Check connections from power supply to I.O. Board 5.. Check power at source, if power is there, proceed, if not check supply power. 5a. Check for power on P3 & P5 on I.O. board. If present, proceed, if not, check fuses F1 & F2. 5b. If fuses are OK, replace I.O. board. 5c. Check power on connector to power supply, if there, proceed, if not, replace cable. 5d. Check power supply fuse, if OK proceed, if not, replace fuse. 5e. Check for 5VDC across Red and Black wires on I.O. board, if OK proceed, if not, replace power supply.
Blow down LED stays ON	<ol style="list-style-type: none"> 1. Conductivity of water is above control point, 	<ol style="list-style-type: none"> 1. Check blow down line for clogged strainer, dirty or

	<p>blowdown restricted.</p> <p>2. Chemicals or process liquid at probe</p> <p>3. Conductivity of sample stream higher than system conductivity, sample stream restricted.</p>	<p>defective solenoid.</p> <p>2. Check injection point, should be downstream of probe.</p> <p>3. Clean strainer and sample line.</p>
No Relay Output	<p>1. Blown fuse</p> <p>2. Bad relay</p> <p>3. No flow</p> <p>4. Limit Timer exceeded</p>	<p>1. Replace output fuse on I.O. board.</p> <p>2. Replace I.O. board.</p> <p>3. Check flow and flow switch</p> <p>4. Reset Limit Timer</p>
Conductivity of Controller Decreases while System conductivity Increases	<p>1. Fouled probe</p>	<p>1. Clean probe</p>
Conductivity of System stays lower than Control Point, never if rarely blows down.	<p>1. Uncontrolled blow down</p>	<p>1. Blow down valve leaking do the following:</p> <p>1a. Re-align ball valve, if leaking by the ball valve</p> <p>1b. Clean solenoid valve.</p> <p>1c. Close manual blow down valve.</p> <p>1d. Fix leaks in system.</p>
Conductivity reading drifts lower than sample tested.	<p>1. Probe fouled, calibration procedure not carefully followed.</p>	<p>1. Clean probe. Re-calibrate. If decrease continues necessitating frequent cleanings, try calibrating without cleaning.</p>

	2. Calibration point not near set point	2. Re-calibrate with solution near set point.
Blow down Relay cycles On and Off	1. Air in sample line 2. Differential too tight	1. Bleed air off. Close isolation valves 2. Widen differential between Set Point and Control Points. 2a. Check solenoid location (plumbing).
Controller not blowing down with high conductivity	1. No flow 2. Relay bad or fuse bad	1. Check flow switch and flow. 2. Check relay and fuse.
Chemical pump not activating	1. Fuse bad 2. Pulse Timer	1. Replace fuse. 2. Renew flow through water meter, replace water meter register, replace wiring.
Readings drifting	1. Dirty electrode	1. Clean probe.
Conductivity reads Zero	1. Air lock 2. Corroded probe 3. Wiring connection loose 4. Improper calibration 5. Bad Intellisense	1. Review plumbing 2. Replace. 3. Check and rewire if necessary. 4. review procedures. 5. Replace Intellisense
pH will not calibrate	1. Fouled probe 2. Defective probe 3. Incorrect calibration	1. Clean probe. 2. Replace probe 3. review procedures
pH output relay is off and pH is not being controlled	1. Limit timer timed out	1. Reset timer
pH output stays on and pH is not being controlled.	1. Restriction in sample line 2. Pump lost prime 3. Chemical drum empty	1. Clean sample line. 2. Prime pump 3. Replenish chemicals

pH reading does not change after calibration or goes to maximum	<ol style="list-style-type: none"> 1. Bad probe 2. Bad probe connection 3. Bad Intellisense 	<ol style="list-style-type: none"> 1. Replace 2. Check connections and or replace cable 3. Replace Intellisense
4-20mA input/output have no readings	<ol style="list-style-type: none"> 1. Input/output disabled 2. MPIO not supplying power 3. Improper calibration 	<ol style="list-style-type: none"> 1. See Input Setup and Calibration Sec. 6 2. Turn power On, see sec 6 3. Recalibrate
Service Light is ON.	<ol style="list-style-type: none"> 1. Scheduled maintenance is due. 	<ol style="list-style-type: none"> 1. Perform scheduled maintenance. 1a. Reset Service Schedule Reminder in “View Service” Menu
USB Object doesn't appear on display and Intellisense Power light is ON and not flashing.	<ol style="list-style-type: none"> 1. Communications lost 	<ol style="list-style-type: none"> 1. Cycle power to rebuild the network. 1a. Check cable connections. 1b. Replace cable. 1c. Replace IntelliSense. 1d. Replace controller.
USB Object doesn't appear on display and Intellisense Power light is OFF.	<ol style="list-style-type: none"> 1. Power Fault 	<ol style="list-style-type: none"> 1. Check controller power. 1a. Check cable connections. 1b. Replace cable. 1c. Replace IntelliSense. 1d. Replace controller.
RS422 Object doesn't appear on display and Intellisense Power light is ON and not flashing.	<ol style="list-style-type: none"> 1. Communications lost 	<ol style="list-style-type: none"> 1. Cycle power to rebuild the network. 1a. Check cable connections. 1b. Replace cable. 1c. Replace USB to RJ45 Adapter. 1d. Replace IntelliSense. 1e. Replace controller.

RS422 Object doesn't appear on display and Intellisense Power light is OFF.	1. Power Fault	1. Check controller power. 1a. Check cable connections. 1b. Replace cable. 1c. Replace USB to RJ45 Adapter. 1d. Replace IntelliSense. 1e. Replace controller.
Probe 1 or Probe 2 Disabled Invalid appears on display. Alarm light is ON	1. Cut cable 2. Unplugged cable 3. Communication lost	1. Replace cable 2. Check cable connections 3. Cycle power to rebuild the network. 3a. Check cable connections. 3b. Replace cable. 3c. Replace USB to RJ45 Adapter. 3d. Replace IntelliSense. 3e. Replace controller.
IntelliSense Red Alarm is ON.	1. Probe problem	1. Check probe type matches Intellisense type. 1a. Check probe ID resistor value and location on terminal block. 1b. Replace probe.
IntelliSense Red Alarm is ON.	1. Internal circuit problem	1. Replace Intellisense.
Controller has RED Alarm LED On.	1. Alarm condition exists	1. Enter "View Alarms" menu to check alarm condition.
Controller has RED Alarm LED On and output relay deactivated.	1. Limit Timer Exceeded	1. Press "Clear Alarm" soft key.

11.0 PROBE DIAGRAMS

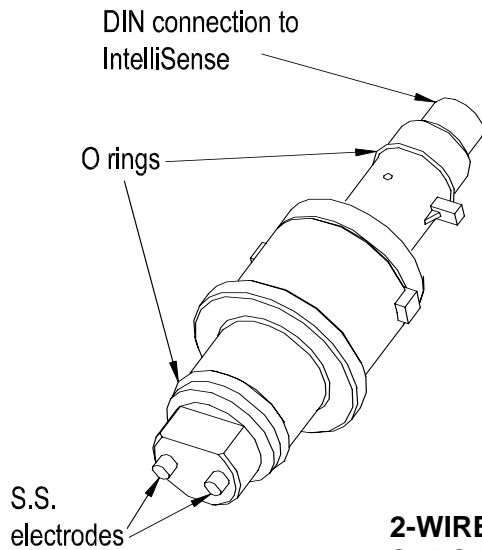

2-WIRE STAINLESS STEEL ELECTRODE PROBE SPECIFICATIONS

Pressure Rating	125 PSI (8.6 BAR)
Temperature Rating	125° F (51.7° C)
Temperature Compensation	32°F (0.0°C) to 105°F (40.6°C)
Construction	CPVC/Stainless Steel
Cell Constant	1.0

Fig. 25

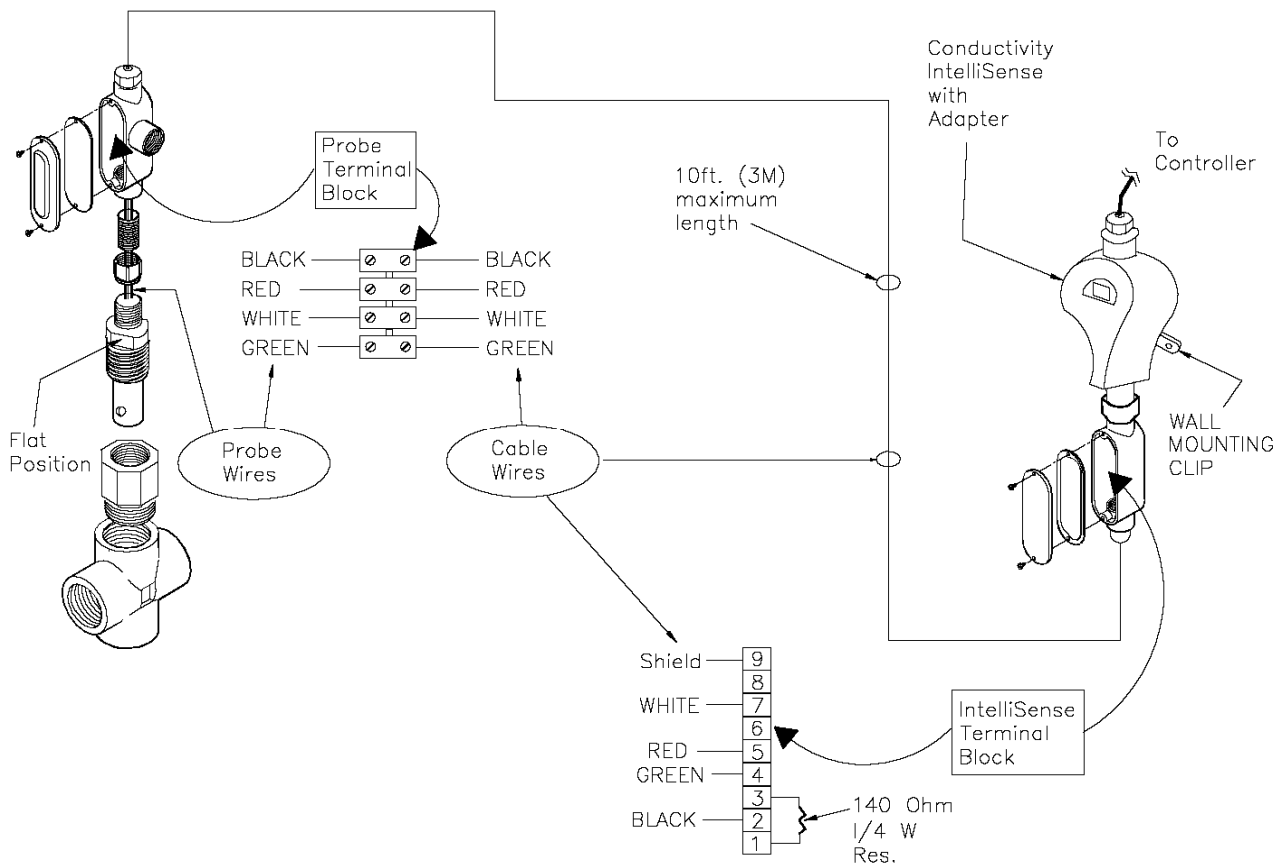

Fig. 26

HI-PRESSURE/TEMP. CONDUCTIVITY PROBE SPECIFICATIONS

Pressure Rating	250 PSI (17.3 BAR)
Temperature Rating	32° F to 392° F (0° C to 200° C)
Temperature Compensation	32°F to 400°F (0° C to 204°C)
Construction	Stainless Steel 316 with PEEK
Cell Constant	1.0



IMPORTANT! For proper conductivity readings, make sure that the flat on the probe body is perpendicular to the water flow. (See drawing below)



Wires from the probe are pre-wired to the Probe Terminal Block in the junction box. Using recommended shielded (Consolidated Wire 5731-CL) cable, make connection from the IntelliSense Terminal Block to the Probe Terminal Block. The maximum length of the shielded cable is 10 feet (3.05 m). (See drawing below).

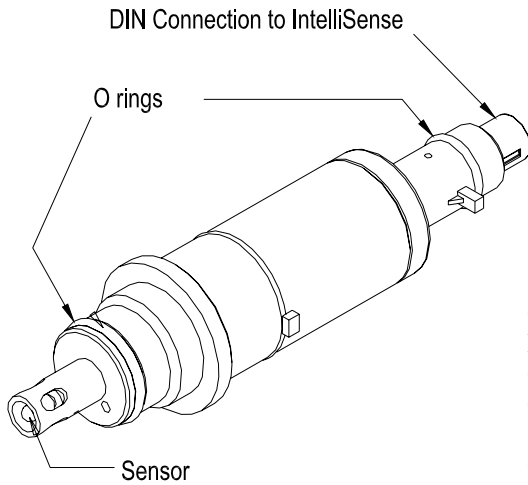

ORP PROBE SPECIFICATIONS

ORP Range -2000mV to 2000mV
 Response Time < 20 Sec. (95% Response)
 Operating Temp. Range ... 23° F (-5° C) to 176° F (+80° C)
 Operating Pressure Range .. 50 psi (3.4 BAR) @ 176° F (80°C)
 100 psi (6.8 BAR) @ 77° F (25°C)
 Construction CPVC
 Single Junction
Max. Flow Rate..... 10 gpm (37.9 liters/min.)

Fig. 28

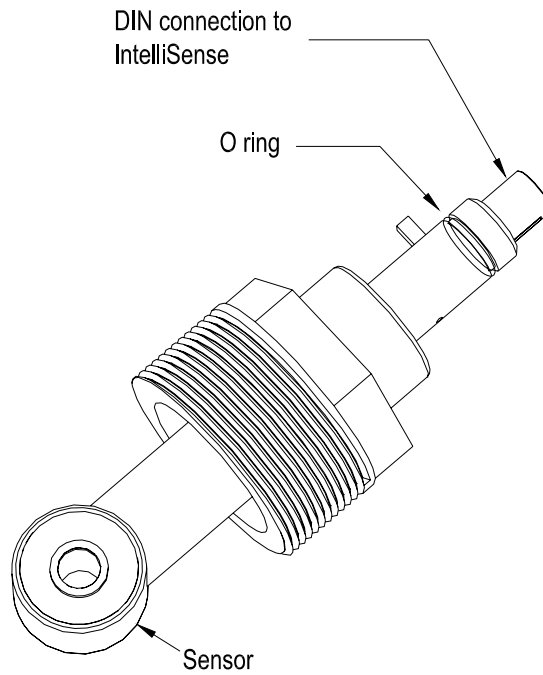

TOROIDAL PROBE SPECIFICATIONS

Conductivity Range500 to 200,000 uS/cm
 Temperature Range.....32-221°F (0-105°C)
 Pressure Max.....100 psi (6.8 Bar)

Fig. 29

INTELLISENSE ADAPTER

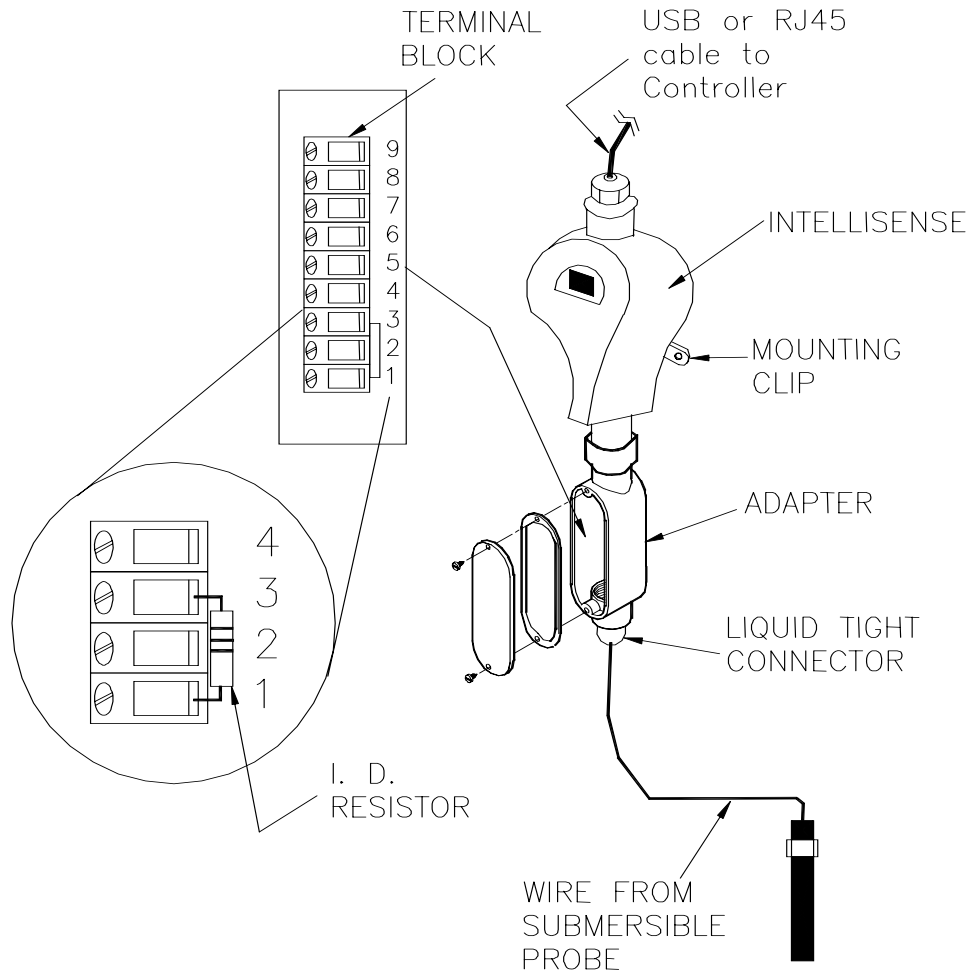

Fig 30

All submersible probes and the boiler probes are attached to the system via the *IntelliSense* Adapter. Remove the screws and remove the cover. Next pass the cable from the probe through the liquid tight connector located on the bottom of the box. Strip the wires and attach them to the terminal block using the chart below (see Fig 31). Probe wire colors are in parentheses. While most Vision probes have an **internal** identifying (I.D.) resistor, some probes require an **external** identifying (I.D.) resistor.

Terminal #	pH	ORP	2 WIRE CONDUCTIVITY	BOILER CONDUCTIVITY	TOROIDAL CONDUCTIVITY
1	Probe I.D. Resistor (white)	Probe I.D. Resistor (white)	Probe I.D. Resistor (brown)	Probe I.D. Resistor (140 Ω)*	Probe I.D. Resistor (64.9 Ω)*
2	n/a	n/a	Electrode (red)	Electrode (black)	Drive (+) (red from red sleeve)
3	Probe I.D. Resistor (green)	Probe I.D. Resistor (green)	Probe I.D. Resistor (clear)	Probe I.D. Resistor (140 Ω)*	Probe I.D. Resistor (64.9 Ω)*
4	Temp. Comp. (red)	Temp. Comp. (red)	Temp. Comp. (white)	Temp. Comp. (green)	Temp. Comp. (green from green sleeve)
5	pH Signal (gray)	ORP Signal (gray)	Electrode (black)	Electrode (red)	Sense (+) (white from white sleeve)
6	n/a	n/a	n/a	n/a	Sense (-) (black from white sleeve)
7	Temp. Comp. (black)	Temp. Comp. (black)	Temp. Comp. (clear)	Temp. Comp. (white)	Temp. Comp. (black from green sleeve)
8	pH Reference (violet)	ORP Reference (violet)	n/a	n/a	Drive (-) (black from red sleeve)
9	Shield/Drain (clear)	Shield/Drain (clear)	Shield	Shield	Shield (3 clear)

Fig. 31



NOTE

An identifying (I.D.) resistor must be installed between Terminals #1 and #3 for proper operation.* This tells the system the type of probe installed. Make sure that you match the IntelliSense with the probe, i.e., a pH *IntelliSense* must be used with a pH probe.



NOTE

*Applicable to boiler and toroidal conductivity probes - they do not have internal identifying resistors. This also applies to all probes from other manufacturers.

Probe I. D. Resistor Value Table (¼ Watt, 1% tolerance)

PROBE TYPE	OHMS
pH	1,000*
ORP	261*
2-WIRE CONDUCTIVITY	140*
2-WIRE BOILER CONDUCTIVITY	140
TOROID CONDUCTIVITY	64.9

12.0 SPECIFICATIONS

12.1 General

Power Input	100-240 VAC @ 50/60 Hz 30 VA.
Control Output	Line voltage @ 600 VA (5 amps @ 120 VAC) per relay.
Enclosure Pre-wired	High impact resistant ABS designed to NEMA 4X (IP65), with convenient molded receptacle cords and power cord with molded plug for electrical connections.
Enclosure Conduit	High impact resistant ABS designed to NEMA 4X (IP65), factory predrilled with easily accessible terminals for hard wiring.
Display graphics display).	64 X 128 pixel dot matrix backlit display (Full
Power Switch	Internal
H/O/A Switches	Front panel keypad.
Security Code	Standard.
Environment	Ambient temp. 0°F (-17.8°C) to 122°F (50°C); relative humidity 0 to 100%.Dimensions Width cm) x Depth 6.0" (15.24)
10.7" (27.18 cm) x Height 8.2" (20.83	
Controller Weight	5 lbs. (2.27 kg)
Shipping Weight	8 lbs. (3.63 kg)
Flow Switch	Connection provided. Function activated in controller configuration.
Inputs model).	2 analog* and 4 probe (max. - depends on
Outputs	2 analog* and 5 relays (onboard max.).



***Analog Inputs and Outputs are optional.**

12.2 Conductivity (2-WIRE)

Probe	Temperature compensated (Pt 1000 RTD) from 45°F (7.2°C) to 125°F (52°C), quick-release 3/4" (19.05 mm) CPVC flow tee. Pressure 125 psi (8.6 BAR) @ 125°F (52°C).
Range	0 to 20,000 µS/cm.
Accuracy	+/- 1% of full scale, at point of measurement, excluding probe.
High/Low Alarm	Independently adjustable high and low (depends on operating mode selection).
Limit Timer	Adjustable in 1-minute increments up to 23:59:59.; Latched Alarm.

12.3 Conductivity (High Pressure/Temperature)

Probe:	Temperature compensated (Pt 1000 RTD) from 60°F (10°C) to 392°F (200°C). Pressure 250 psi (17.3 BAR).
Range:	0 to 20,000 uS/cm.
Accuracy	+/- 1% of full scale, at point of measurement, excluding probe.
Limit Timer	Adjustable in 1-minute increments up to 23:59:59.; Latched Alarm.

12.4 Conductivity (Toroidal)

Probe	Temperature compensated (Pt 1000 RTD); Tape wound core toroid; polypropylene body.
Temp. Range	32°F to 221°F (0 to 105°C)
Pressure Max.	100 psi (6.89 BAR)
Range	500 uS to 200,000 uS/cm.

12.5 pH Specifications

Probe	3.5M KCl-AgCl gel reference. Provided with 3/4" (19.05 mm) CPVC flow tee 50 psi (3.4 BAR) @ 185° F(85° C).
Set point acid and	Dual set point with independent relays for caustic.
Range	0 to 14 pH.
Accuracy	+/- 1% of full scale, at point of measure, excluding probe.
High/Low Alarm	Independently adjustable high and low.
Limit Timer	Adjustable in 1 minute increments up to 23 hours, 59 minutes; Latched Alarm.

12.6 ORP Specifications

Probe	3.5M KCl-AgCl gel reference. Provided with 3/4" (19.05 mm) CPVC flow tee 50 psi (3.4 BAR) @ 185°F (85°C).
Set point	Select rising or falling, factory set falling 400 mV.
Range	-2000 mV to 2000 mV.
Accuracy	+/- 1% of full scale, at point of measure, excluding probe.
Differential	Adjustable; factory setting 50 mV.
High/Low Alarm	Independently adjustable high and low.
Limit Timer	Adjustable in 1 minute increments up to 23 hours, 59 minutes; factory set at 1:30 hr/min.

12.7 Summary of Soft keys

Menu	When pressed, Main Menu is displayed
Home	When pushed, returns displayed menu back to Start Up screen.
ENTER	Selects highlighted object and enters displayed value into the instrument.
Arrow Up	Used to move prompt to line above current line and to press scroll through. Alphanumeric characters.
Arrow Down	Used to move prompt to line below current line and to scroll down through alpha-numeric characters.
Arrow Left	Used with [Shift] key to move cursor to the left.
Arrow Right	Used to move the prompt to the right.
Shift	When pressed, displays more soft keys
Cancel	Cancels programming and returns to previous screen.
Back	When pressed returns to previous screen.
Relay Keys	Hand/Off/Auto (HOA) witches, depressing key: ONCE Forces corresponding output relay on for five minutes; LED color amber. 2(X) Forces corresponding output relay off until power is cycled or key pressed; LED color red. 3(X) Returns control to automatic; LED off if within set point, green if out of set point.

12.8 Summary Of LED Indicator Lights

Power Indicator	Illuminates green when power is supplied to unit.
Service Indicator	Illuminates orange when programmed service time is reached.
Alarm Indicator	Illuminates red when an alarm condition is present.
Relay Indicators	AMBER if forced on. RED If forced off. OFF If in auto mode and control function is not automatically activated. GREEN If activated automatically

13.0 OPTIONAL EQUIPMENT

13.1 IntelliScan (Calibrator)

The *IntelliScan* calibrator enables you to enter your calibration information remotely into your system via the *IntelliSense* with a simple press of a button. It can do 1-Point or 2-Point calibration. You can also calibrate without access to the main controller.

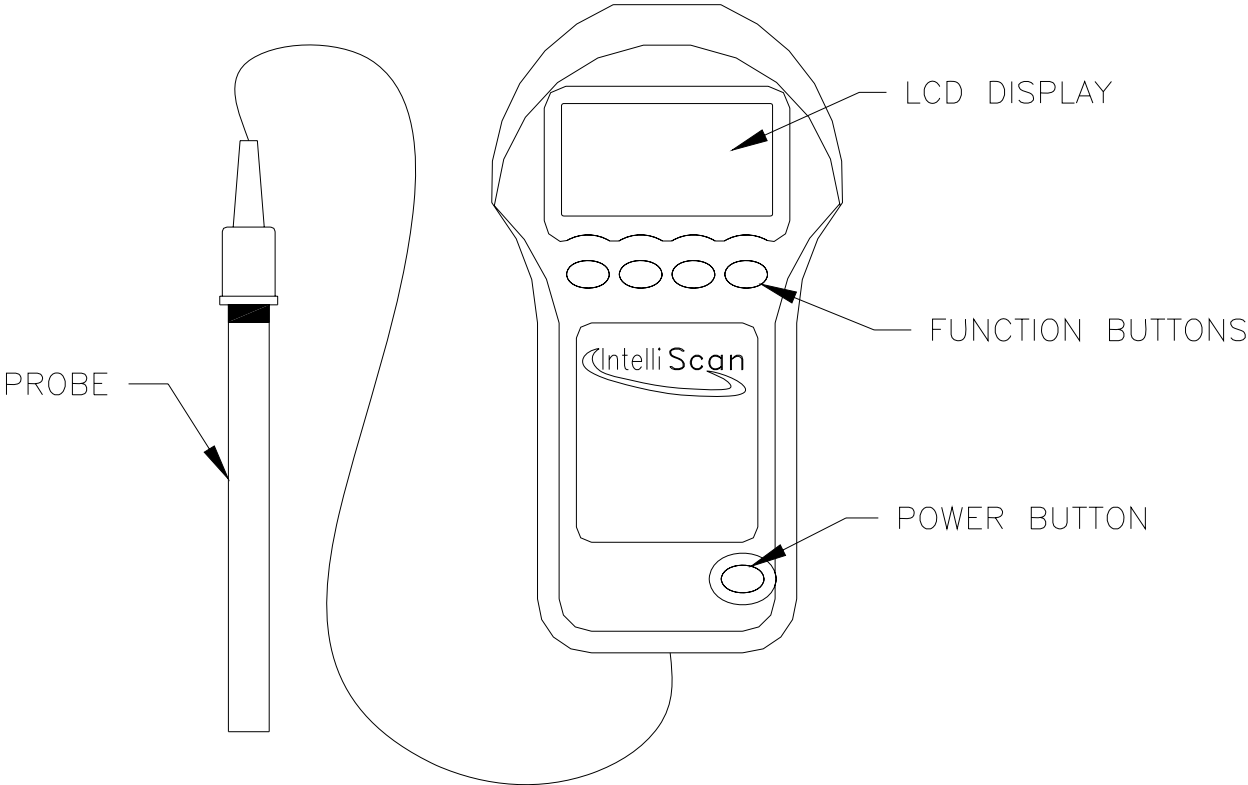

Fig. 32

13.1.1 SPECIFICATIONS

Display:	128 x 64 Graphics LCD w/ backlighting
Battery Type:	AA battery (4 required)
Ports and Connectors:	USB-B 8 Pos. Cir. DIN IRDA Transceiver
Physical:	Length 190.5 mm (7.5 inches) Width 101.6 mm (4.0 inches) Height 50.8 mm (2.0 inches) Weight 317.5 g (0.7 lb)
Temperature range:	0° to 40°C (32° to 104°F)

13.1.2 BATTERY INSTALLATION

- The batteries must be installed before using. To install the batteries:
- First make sure that the unit is OFF.
- Loosen the center screw on the battery compartment door.
- Place the (4) batteries in the compartment. Make sure that batteries match the polarity signs: (+) and (-)
- Replace the battery compartment door.

13.1.3 PROBE INSTALLATION

The probe is installed by plugging the DIN connector on the end of your probe into the DIN receptacle located on the bottom of your *IntelliScan*



Make sure that the alignment tab matches both connectors.

13.2 IntelliScan Setup

Press the Power button to turn the unit on. Then press the **SETUP** button.

13.2.1 Set Date

Press [ENTER] to enter the **SET DATE MENU**. Use the [^], or [V] keys to select the month and press [ENTER] to save. Then use function buttons to enter date and press [ENTER] to save. Then use the function buttons to enter the year and press [ENTER] to save.

13.2.1 Set Time

Press the [V] key until **SET TIME** is highlighted and press [ENTER]. Use the function keys to set the time and then press [ENTER] to save.

13.2.3 Set Date/Time Format

Press the [V] key until **SET DATE/SET TIME** is highlighted and press [ENTER]. Use the function keys to select the Date format and then press [ENTER] to save. Time is now highlighted. Use the [^], or [V] key to choose your format and press [ENTER] to save.

13.2.4 Calibrate the Calibrator

IntelliScan Calibrator is calibrated at the factory, however, if there is a need to re-calibrate it is recommended that you use standard solutions in the calibrating process. For pH, the standard buffers are 4, 7 and 10. For ORP, the standards are 100 and 465 mV.

From the Setup screen, press [V] until **CALIBRATE THE CALIBRATOR** is highlighted and press [ENTER]. Use the function keys to select 1 or 2-point calibration and then press [ENTER] to save. **PROBE** is now highlighted. Use the [^], or [V] keys to choose your probe and press [ENTER] to save. Place your probe into the standard. When the reading is stable, press [NEXT]. Use the [^], or [V] and [>] keys to enter the value and press [ENTER] to save.

With a 2-point sample, you should rinse the probe with the next standard solution before entering the second point. For temperature, make sure that you wait 2 to 5 minutes between temperature readings.

13.2.5 Set Language

Press [ENTER] to enter the **SET LANGUAGE MENU**. Use the [^],or [V] keys to select the language and press [ENTER] to save.

13.2.6 Set Temp Format

Press [^],or [V] down until **TEMP FORMAT** is highlighted and press [ENTER]. Use the function keys to select **C** or **F** and then press [ENTER] to save.

13.2.7 Set LCD Contrast

Press [^],or [V] down until **SET LCD CONTRAST** is highlighted and press [ENTER]. Use the function keys to adjust the contrast level up or down, then press [HOME] to save.



Using the *IntelliScan* in a high frequency ERF environment may cause the unit to lockup. If this situation occurs, simply recycle power and resume the calibration procedure.

13.3 Using your IntelliScan to Calibrate your IntelliSense

With your *IntelliScan* calibrator you can calibrate probes without having access to your controller. This is done using IRDA technology. The directions are as follows:

13.3.1 IntelliScan System Calibration

- Obtain a sample of system water from a sample valve.
- Place your *IntelliScan* probe into the sample and note the reading.
- Press either the 1-POINT or the 2-POINT CAL button.
- Select the probe type, **Conductivity, pH or ORP**. Press [ENTER]. Then aim your calibrator at the IntelliSense for the probe you are calibrating. Look for the (O) icon in the upper right hand corner of the display. This indicates that the two devices are communicating. The current reading of your system's probe will now be displayed.



To avoid crosstalk when calibrating an *IntelliSense* that is close to another *IntelliSense*, e.g., with panel mounted flow assemblies, keep the *IntelliScan* within 6 to 10 inches (15.2 to 25.4 cm) of the *IntelliSense* that you are calibrating.

- After the reading is stable for 10 seconds, press [NEXT].
- You will see the **LAST PROBE VALUE**, which is what your system is seeing.
- If this reading is different than the one from your *IntelliScan*, enter this **ACTUAL VALUE** that you obtained in step 2 using the [^],[V], [▶] keys to enter this value.
- Look for the (O) icon in the upper right hand corner of the display. This indicates that the two devices are communicating. When the (O) is blinking, you are ready to transmit the **ACTUAL VALUE** to the *IntelliSense*.
- Follow the on screen instructions and press [Transmit]
- Calibrator will display "Calibration Successful" if the new value was accepted.
- 12 Press [ENTER] to return to the **HOME** screen.

13.4 Relay Expansion Box

The Relay Expansion Box adds 4 more output relays that you can use to control your processes. The Relay Expansion box has 4 HOA keys and 4 status LED 's and operate the same as those on the main unit. The Relay Expansion box allows you to control pumps up to 1000 feet away (RS422 connection required).

13.4.1 Installation

Mount the box near a 115 VAC outlet using the four mounting tabs and plug in the line cord. For conduit models, holes are provided on the bottom of the box. Use 16 AWG (1.5mm²) or 18 AWG (1.2mm²) for conduit power and load connections. To access the connections, remove the front panel held in place by four screws and set aside. Wire according to the chart below.

TB1		TB2		TB3		TB4		TB5	
MAIN POWER		RELAY #1		RELAY #2		RELAY #3		RELAY #4	
Disc.	Position	Disc.	Position	Disc.	Position	Disc.	Position	Disc.	Position
Hot	3	N.C.	4	N.C.	4	N.C.	4	N.C.	4
Gnd.	2	N.O	3	N.O	3	N.O	3	N.O	3
RTN	1	Gnd.	2	Gnd.	2	Gnd.	2	Gnd.	2
		RTN	1	RTN	1	RTN	1	RTN	1



Hold the panel face down so the four actuator pins remain in place.

NOTE

13.4.2 INSTALLING USB/Cat 5E CABLES TO THE RELAY EXPANSION BOX

The Relay Expansion Box has either a USB or RJ45 input connector located on top behind a liquid tight connector. To make this connection, follow these instructions:

- Remove the outside compression nut from one of the large liquid tight connectors.
- Pass your USB/Cat 5E cable through the outside nut and put aside. Remember that you will be replacing this nut so please note orientation of the nut.
- Using a finger, push out the white plug. Note that the plug has a hole and is cut to allow for the cable to be slipped through. Also, note the orientation of the plug.
- Pass the cable connector through the compression nut and the liquid tight connector.
- Plug the cable into the USB/RJ45 connector on top of the pcb.
- Slip the cut white rubber plug over the cable noting the orientation, cupped side toward the connector and slid it back into the liquid tight connector. This may take some effort to clear the plastic tabs. Make sure that the plug is fully seated.
- Replace the compression nut.

13.4.3 INSTALLING USB/Cat 5E CABLES TO THE CONTROLLER

Your process control instrument has 3 USB inputs for attaching probes and accessories. These are located behind the front panel.

- Remove the 4 panel screws and set aside.
- Lift off the front panel and place it face down above the box.

- Remove the outside compression nut from one of the 3 large liquid tight connectors.
- Pass your USB/Cat 5E cable through the outside nut and put aside. Remember that you will be replacing this nut so please note orientation of the nut.
- Remove the protective disk revealing a white rubber plug.
- Using a finger, push out the white plug. Note that the plug has a hole and is cut to allow for the cable to be slipped through. Also, note the orientation of the plug, cupped side toward the controller.
- Slip the plug onto your cable allowing about 12 in. (30.5 cm.) of slack. Make sure that the plug is in the same orientation.
- Pass the cable connector through the liquid tight and replace the rubber plug. This may take some effort to clear the plastic tabs. Make sure that the plug is fully seated.
- Replace the compression nut.
- Next, plug your cable into one of the 3 available USB ports.
- Remember that if you have a CAT 5E cable, a **USB to RJ45 Adapter** must be used to convert the cable to USB.
- Replace the front panel and insert the 4 screws.

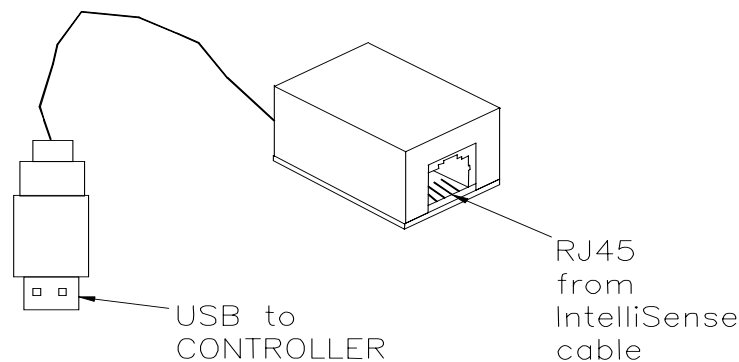

Fig.33 - USB to RJ45 Adapter

13.4.4 Setup

Apply power to your system and the new object(s) are automatically added to your network. They will now be configurable and available for use to control your processes. Refer to **Section 4, Controller Setup** to configure your objects. Once you have connected the USB/Cat 5E cable, the Power LED on the Relay Box will start flashing (see note below).



The Power LED shows network power and does not indicate the presence of AC line voltage.

NOTE

13.5 USB Hub

The USB Hub allows for the addition of 7 more *Objects* to your system.

13.5.1 Installation

Mount the NEMA 4X box near the 115/230 VAC outlet and plug in the line cord.



The USB Hub must be connected to the same power source as the controller.

To make the connections to the hub, open the latch and open the front cover. The USB cable from your controller should be fed through the liquid tight connector located on the right side of the box. This should be plugged into the ROOT PORT connection on the USB hub. The cables to your *IntelliScense* should pass through the bottom and left side connectors. These USB cables should be connected to the 1 – 7 PORT connections on the USB hub.

Make sure that you disconnect power to the controller before removing its front panel and then plug the other end of your cable into a USB connector located behind the front panel of the controller.

13.5.2 INSTALLING USB CABLES FROM YOUR INTELLISENSE TO THE USB HUB

The USB Hub has 7 USB port connectors. To make a connection, follow these instructions:

- To make the connections to the hub, release the latch and open the front cover.
- Remove the outside compression nut from the large liquid tight connector.
- Pass your USB cable through the outside nut and put aside. Remember that you will be replacing this nut so please note orientation of the nut.
- Using a finger, push out the white plug. Note that the plug has a hole and is cut to allow for the cable to be slipped through. Also, note the orientation of the plug.
- Pass the cable connector through the compression nut and the liquid tight connector.
- Plug the cable into one of the seven PORTS on the hub.
- Slip the cut white rubber plug over the cable noting the orientation, cupped side toward the connector and slid it back into the liquid tight connector. This may take some effort to clear the plastic tabs. Make sure that the plug is fully seated.
- Replace the compression nut.

13.5.3 INSTALLING USB CABLES TO THE CONTROLLER

Your process control instrument has 3 USB inputs for attaching probes and accessories. These are located behind the front panel.

- Remove the 4 panel screws and set aside.
- Lift off the front panel and place it face down above the box.
- Remove the outside compression nut from one of the 3 large liquid tight connectors.
- Pass your USB cable from the HUB through the outside nut and put aside. Remember that you will be replacing this nut so please note orientation of the nut.
- Remove the protective disk revealing a white rubber plug.
- Using a finger, push out the white plug. Note that the plug has a hole and is cut to allow for the cable to be slipped through. Also, note the orientation of the plug, cupped side toward the controller.

- Slip the plug onto your cable allowing about 12 in. (30.5 cm.) of slack. Make sure that the plug is in the same orientation.
- Pass the cable connector through the liquid tight and replace the rubber plug. This may take some effort to clear the plastic tabs. Make sure that the plug is fully seated.
- Replace the compression nut.
- Next, plug your cable into one of the 3 available USB ports.
- Replace the front panel and insert the 4 screws.

13.5.4 Setup

Apply power to your system and the new object(s) are automatically added to your network. **The Green LED's indicate that the Hub is operational.** They will now be configurable and available for use to control your processes. Refer to **Section 5, Controller Setup** to configure your objects. If an RS422 connection is used a "USB to RJ45 Adapter" for converting the RS422 signal to USB signal will be required.

Typical Model UV System

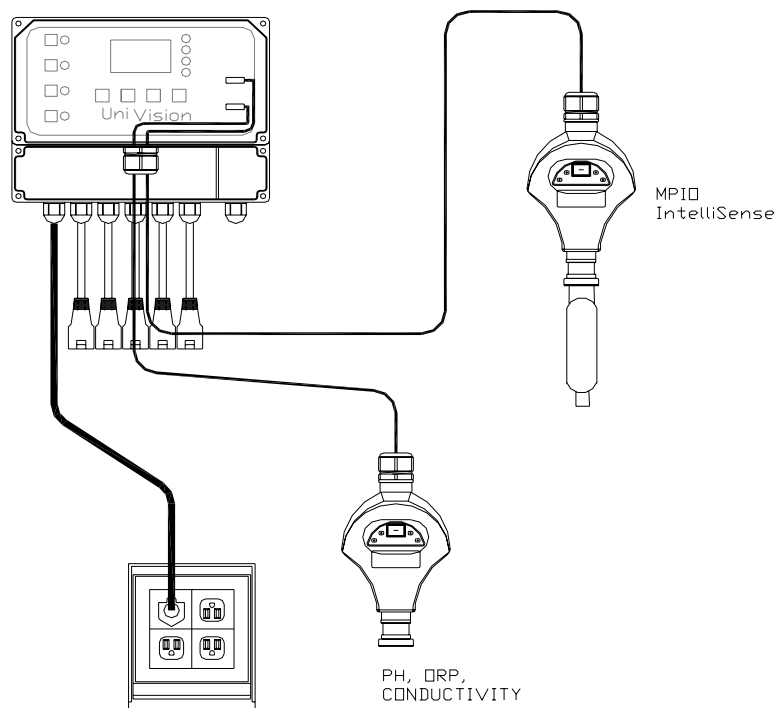

Fig. 34

14.0 ALARM INFORMATION

Alarm Condition Displayed	Causes	Possible Corrective Action
Missing Cond Object	The conductivity probe that was connected to the system, no longer is.	Reconnect missing object and/or reprogram settings for the object.
Missing Flow Object	If the flow input is assigned to an MPIO and the MPIO is disconnected.	Reconnect missing object and/or reprogram settings for the object.
Missing High Relay	Relay assigned to a relay expansion box, or a MPIO that is now disconnected.	Reconnect missing object and/or reprogram settings for the object.
Invalid High Control Point	High control point is not programmed to a valid number.	High Control must be higher then the set point and lower than the high alarm.
Missing Low Relay	Relay assigned to a relay expansion box, or MPIO that is now disconnected.	Reconnect missing object and/or reprogram settings for the object.
Invalid Low Control Point	Low control point is not programmed to a valid number.	Low Control must be lower then the set point and higher than the low alarm.
Invalid Sample Time	Boiler mode Sample Time not set.	Program a valid sample time.
Missing water meter	If the water input is assigned to an MPIO and the MPIO is disconnected.	Reconnect missing object and/or reprogram settings for the object.
Invalid Pulse setting or Invalid Water Level	Pulse Timer setting not entered.	Check programming of timer(s).
Invalid Cycle Time	Percentage Timer setting not entered.	Check programming of timer(s).
Invalid Cycle Percent	Percentage Timer setting not entered.	Check programming of timer(s).
Missing relay	Relay assigned to a relay expansion box, or MPIO that is now disconnected.	Reconnect missing object and/or reprogram settings for the object
Invalid schedule	Calendar Timer setting not entered.	Check programming of timer(s).
Invalid run time	Timer setting not entered.	Check programming of timer(s).
Missing Probe	A probe that was connected to the system, no longer is.	Reconnect missing object and/or reprogram settings for the object.
Invalid High Limit	High control point is not programmed to a valid number.	High Control must be higher then the set point and lower than the low alarm.
Invalid Low limit	Low control point is not programmed to a valid number.	Low Control must be lower then the set point and higher than the low alarm.

Prebleed Limit Timer Expired	Unit went into pre-bleed for the entire limit time programmed for the calendar mode timer, pre-bleed conductivity not reached.	Check system bleed valve operation, check pre-bleed limit time setting.
Bleed Limit Timer Expired	Bleed activated for a period of time longer than the limit time set.	Check system bleed valve operation, check bleed limit time setting.
High Limit Timer Exceeded	High control activated for a period of time longer than the limit time set.	Check system high control device for proper operation, check limit time setting.
Low Limit Timer Exceeded	Low control activated for a period of time longer than the limit time set.	Check system low control device for proper operation, check limit time setting.
Cond Above Alarm Value	Conductivity high alarm.	Check bleed valve operation, or high alarm setting.
Cond Below Alarm Value	Conductivity low alarm.	Check system make up valves/pump operation or low alarm value.
No Flow	No flow detected by flow input.	Check flow switch operation or flow input settings.
Value Above High alarm	Probe high alarm.	Check system high control device for proper operation, check high alarm setting.
Value Below Low Alarm	Probe low alarm.	Check system low control device for proper operation, check low alarm setting.
Post Bleed Limit Timer Expired	Post bleed timer exceeded the limit time.	Check system bleed valve operation, check percent bleed time setting.
Bleed and Feed Limit Timer Expired	Bleed and feed timer exceeded the limit time.	Check system bleed valve operation, check limit time setting.
A/D Converter Failed	<i>IntelliSense</i> failure.	Replace <i>IntelliSense</i>
Boiler/Cooling Power Required	Some program settings are for a cooling tower or boilers only, unit has very likely been set to Process Control mode.	Switch unit back to Cooling Tower or Boiler mode.
Dongle Firmware Out of Date	A dongle attached to the system is using software older than the controller.	Update software.
Object Firmware Out of Date	An object attached to the system is using software older than the controller.	Update software.

15.0 GLOSSARY

Alarm Relay – an electric circuit when triggered by a predetermined signal will activate an externally connected alarm

Analog – a continuous signal that can be used to represent a physical variable, e.g., conductivity, pH, or ORP

Biocide – an agent used to control the growth of algae and other organic substances

Bleed – 1) to release water from the system, used to control conductivity

2) The amount of time the Blow down valve will be held open after a hold period.

Blow down – see Bleed

Blow down Valve – the valve that opens or closes to release water from the system activated by a signal from the Controller

Buffer Solution – a solution with a specific pH value used as a control in calibrating probes.

Calibration – a procedure to match values “read” by probes to actual real world values

Caustic – burning corrosive, a characteristic of some chemicals especially strong alkalis

Chattering – a situation that occurs when relay controlled device repeatedly turns off and on

Chemical Feed Pump – a relay or proportionally controlled pump that disperses chemical into the system (i.e., PULSAtron)

Chemical Metering Pump – see Chemical Feed Pump

Conductivity – the ability of a substance to conduct electrical current, concentrations of dissolved and suspended solids in water directly determine the conductivity of the water

Crosstalk – unwanted signals or interference from another circuit.

Conduit – tubing through which wire is run

Configure – procedure to setup basic functions of the controller, i.e., date, time, set point control, etc.

Contacting head water meter – a water meter that outputs a dry contact signal every time it pulses

Cooling Tower – a structure of various sizes that allows heat to radiate away from the system water

Cursor – See prompt

Cycle Timer – a timing device that can be preset to turn off and on at specific intervals

Differential – also referred to as dead band or hysteresis, this is a range or offset applied to a set point value (see chattering)

Dry Contact – relay contacts without power

Electrodes – or probes, the metal protrusions that measure conductivity in the conductivity probe assembly

Flow Switch – a mechanical switch that provides an electrical contact when the water level rises to a predetermined height

Flow – refers to the movement of water through the system

Flow Assembly – an option, which attaches to the controller and incorporates a flow switch, probe/probe ports, and sample valve

Gate Valve – a type of on/off valve for controlling the flow of liquid that consists of a screw assembly that adjusts a gate that crosses the fluid flow path

GFPPPL – Glass Filled Polypropylene

Hall Effect Water Meter – Solid state flow detection device

Heat Exchanger – a mechanical device that facilitates the transfer of heat between two mediums

HCl – Hydrochloric Acid

High Current – 20 mA signal

Hi Lo Alarm – a function of the controller that signals the user when conditions exceed a predetermined high or low value

HOA – abbreviation for Hands Off Auto

HOA Switches – manual relay switches or keys (relay 1 - 4) located on the control panel of the controller

Hold – the amount of time a sample is captured before reading its conductivity

I. D. Resistor- resistor used with the *MPIO IntelliSense* to identify what probe is in your system

Inhibitor – a chemical or compound used to aid the control of corrosion or scaling in the cooling tower system

Inhibitor Feed – term referring to the disbursement of inhibitor in to the system

Inhibitor Timer – a function of the controller that regulates the amount of time inhibitor is introduced to the system

Initialization – a procedure to reset the controller to original factory conditions

Inorganic Scale Deposits – undesirable precipitate formations within the cooling tower system

Inputs – receptacles or hook-ups for signals delivered to the controller

IntelliSense – Probe interface

IntelliScan - Hand held remote calibrator

Interval – the amount of time between blow down events

I/O Board – a circuit board located at the back of the controller for relay outputs, water meter hook-ups, flow switch, etc.

Isolated Input – an input (analog or digital) that is electrically isolated from main power supply and its ground

(ISO) Isolation Valves – general term that refers to valves in the system used to isolate various components of the system from the main flow

KCl – Potassium Chloride

LED – abbreviation for Light Emitting Diode

Limit Timer – also referred to as lockout timer or feed limit timer, it limits the amount of time output is activated

Line Voltage – voltage equivalent to outside source voltage to the controller

Lockout – intentionally preventing blow down or other functions of the system

Low Current – 4 mA signal

Menu Map – printed document supplied with controller illustrating all menu item locations

Metering Pump – see chemical feed pump

Micro Siemens – unit of measure of conductivity expressed as $\mu\text{S}/\text{CM}$

Motorized Ball Valve – a ball valve with a positioning device activated by an electric motor

MPIO – Multipurpose Input/Output *IntelliSense*, used for 4-20mA input and output, dry contact water meter, Hall Effect water meter and dry output connections

NaOH – Sodium Hydroxide

ORP – Oxidation Reduction Potential, measured in millivolts (mV) to detect and control level of chlorine or other oxidizing agents in system water

Outputs – receptacles or hook-ups for signals originated at the controller

Overfeed – a condition in which the quantity of an ingredient dispersed into the system exceeds the amount desired

Percent Post Blow down – refers to the amount of time as a percentage of blow down time that chemical feed pumps are activated when blow down is deactivated

Percent Timer – also referred to as a cycle timer that runs continuously that activates an output to run as a percent of total cycle time

pH – the measurement of acidity or alkalinity (acid or base) of an aqueous solution

Pre Bleed – refers to the time bleed (or blow down) is executed before biocide feed

Pre Blow down – see Pre Bleed

Program Parameters – the user programmed settings that determine how the controller responds to conditions of the system under control

Prompt – a triangular pointer used to indicate the active menu line

Pulse – the action of a water meter that when equipped with a contact head, can generate a dry contact closure that can be read by the controller

Pulse Timer – a feature of the controller in which a timer accepts pulses from a water meter to actuate a chemical feed pump

Relay Indicators – lights (LED's) located beneath the relay keys on the face of the control panel that indicate the status of individual relays

Relay Expansion Box - Optional accessory that adds 4 additional HOA output relays

RJ45 – Modular 8 connector plug used on Cat 5E communication cables

RS422 – Data communication standard that uses a balanced differential operating mode for stability

Sample – 1) to obtain a quantity of water for test purposes,
2) the amount of time the blow down valve will be held open

Sample Cock – see Sample Valve

Sample Cooler – a small heat exchanger designed to cool a small flow of boiler water to a temperature where it can exist in its liquid state at standard atmospheric pressure (i.e., it is not boiling)

Sample Line – a line through which a portion of the system water flows, where probes and other monitoring devices are located controlled with isolation valves

Sample Stream Flow Assembly – an option (standard on many models) which is a modular assembly that mounts to the controller with quick-release probe(s), flow switch and sample cock or (valve)

Sample Valve – small valve on the flow assembly that provides user a means to drain small quantities of water from the system for testing

Scale/Range – the adjustable monitoring range of the controller in reference to conductivity levels in the system

Security Code – a code that can be entered by the user when configuring the system to secure access to the controller settings

Probe – a device connected to the controller which monitors or measures a characteristic value in the water, like the conductivity

Set point – the user determined value within a monitored range at which the controller initiates action (e.g., activates a relay)

Set point Differential – also referred to as dead band or hysteresis; the offset applied to a set point to prevent chattering of an output relay around a set point

Soft Keys – Buttons on front panel used to input information

Solenoid – an electromagnetically controlled switch

Storage Boot – small protective rubber boot or bottle filled with a junction wetting agent found on the tip of a new pH or ORP probe to keep tip wet during shipment and storage

System Overfeed – usually a malfunction condition where a feed pump fails in the Run (ON) condition

System Parameters – see program parameters

System pH – level of pH in the system water

TDS – abbreviation for Total Dissolved Solids, measured in terms of electrical conductivity ($\mu\text{S}/\text{CM}$)

Temperature Compensation – displays conductivity as if measured at 77°F (25°C)

Temp Probe – used to measure temperature

Toroidal Conductivity – Non-contacting conductivity sensor used for high values

Throttling – the act of adjusting a valve or other flow control device to vary flow rate

Totalizer – a resettable function of the controller that keeps count of the number of water meter pulses

USB Hub - Optional accessory that offers additional USB connections

$\mu\text{S}/\text{CM}$ – conductivity unit of measure. Often referred to as micro Siemens

Water Hammer – a potentially damaging situation that occurs if a valve in the system is opened to quickly, where the action results in a “hammering” effect throughout the system water lines

Y-Strainer – inline filter or screen to remove debris from system flow assembly

16.0 MENU MAP

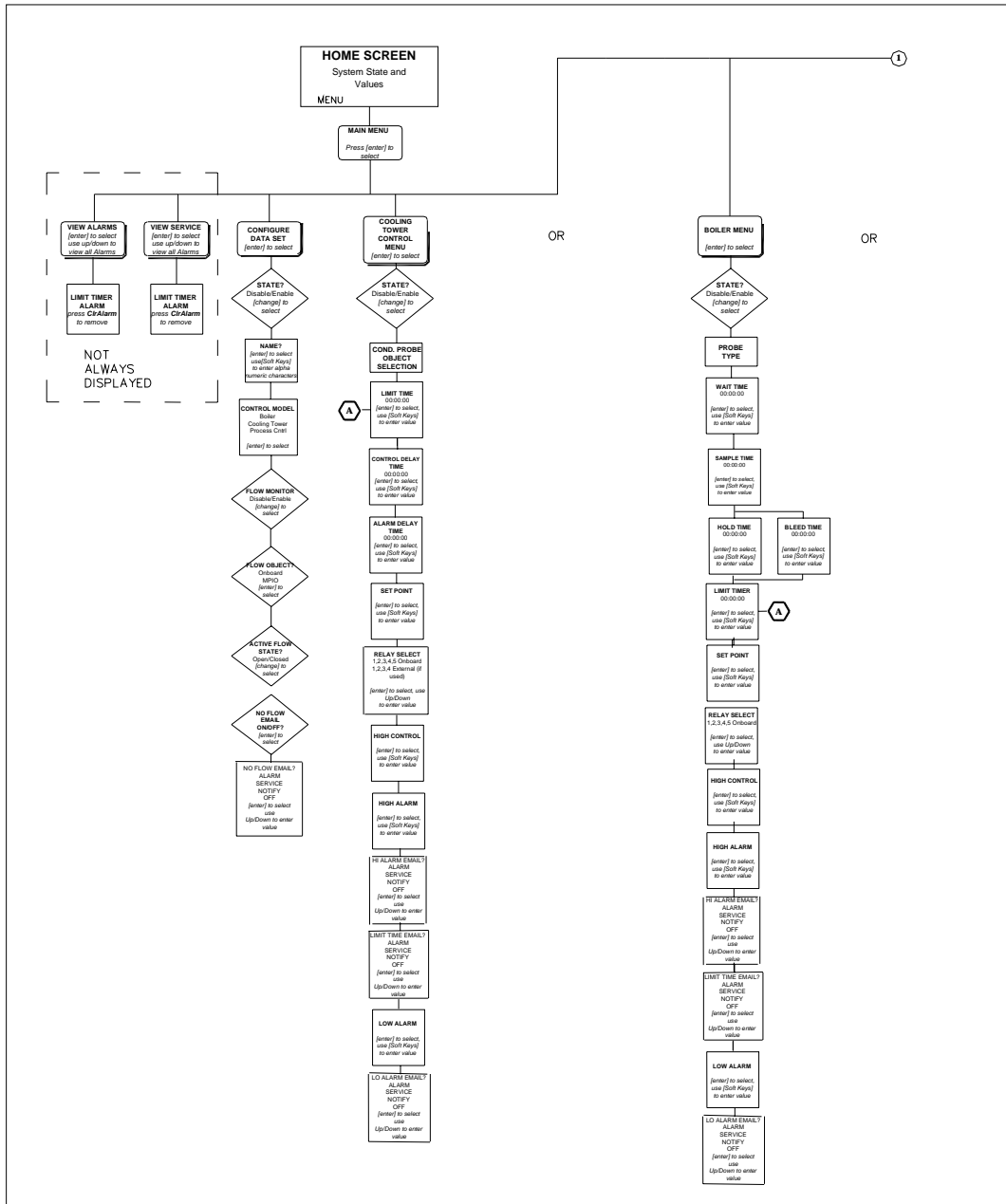

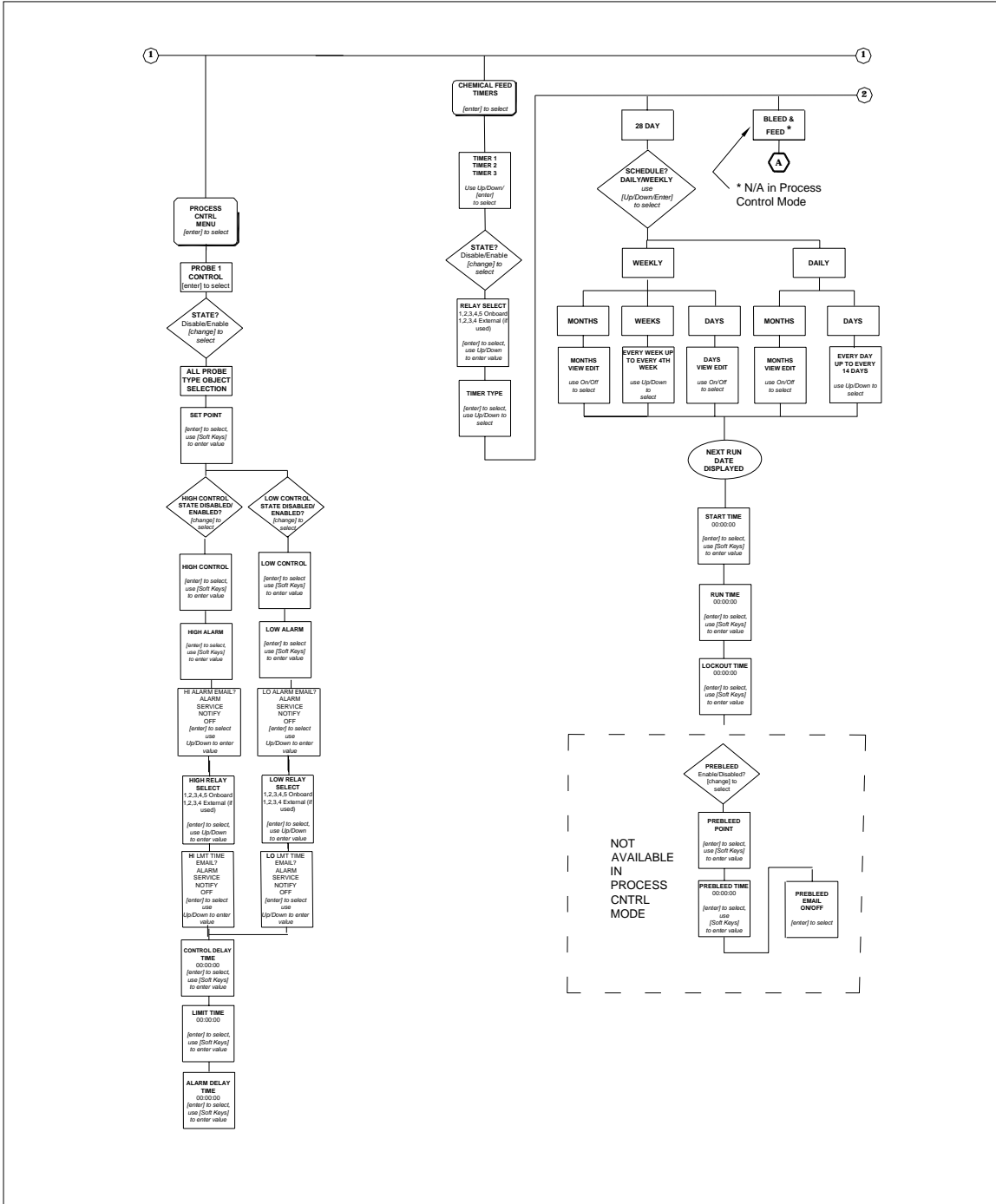

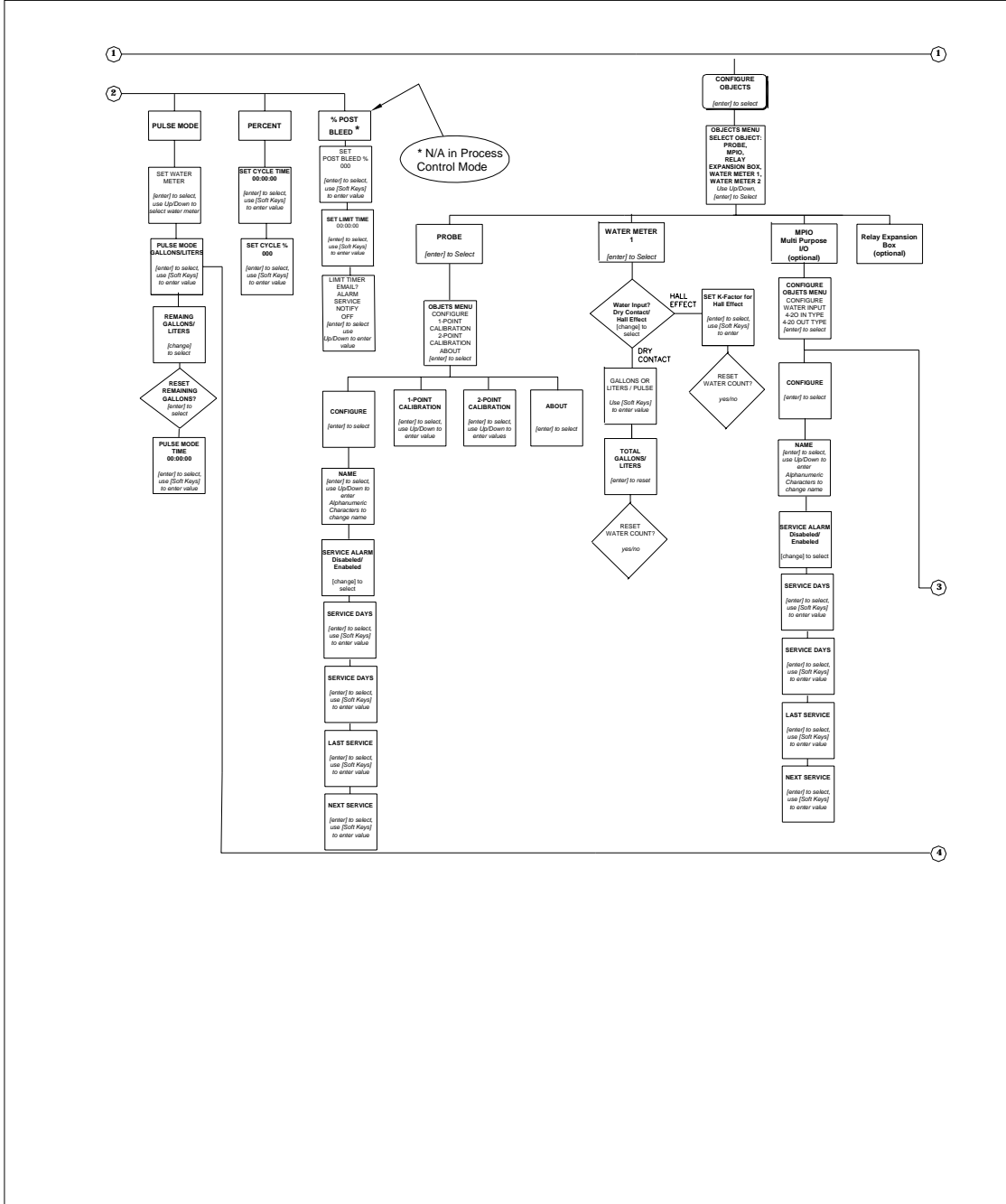

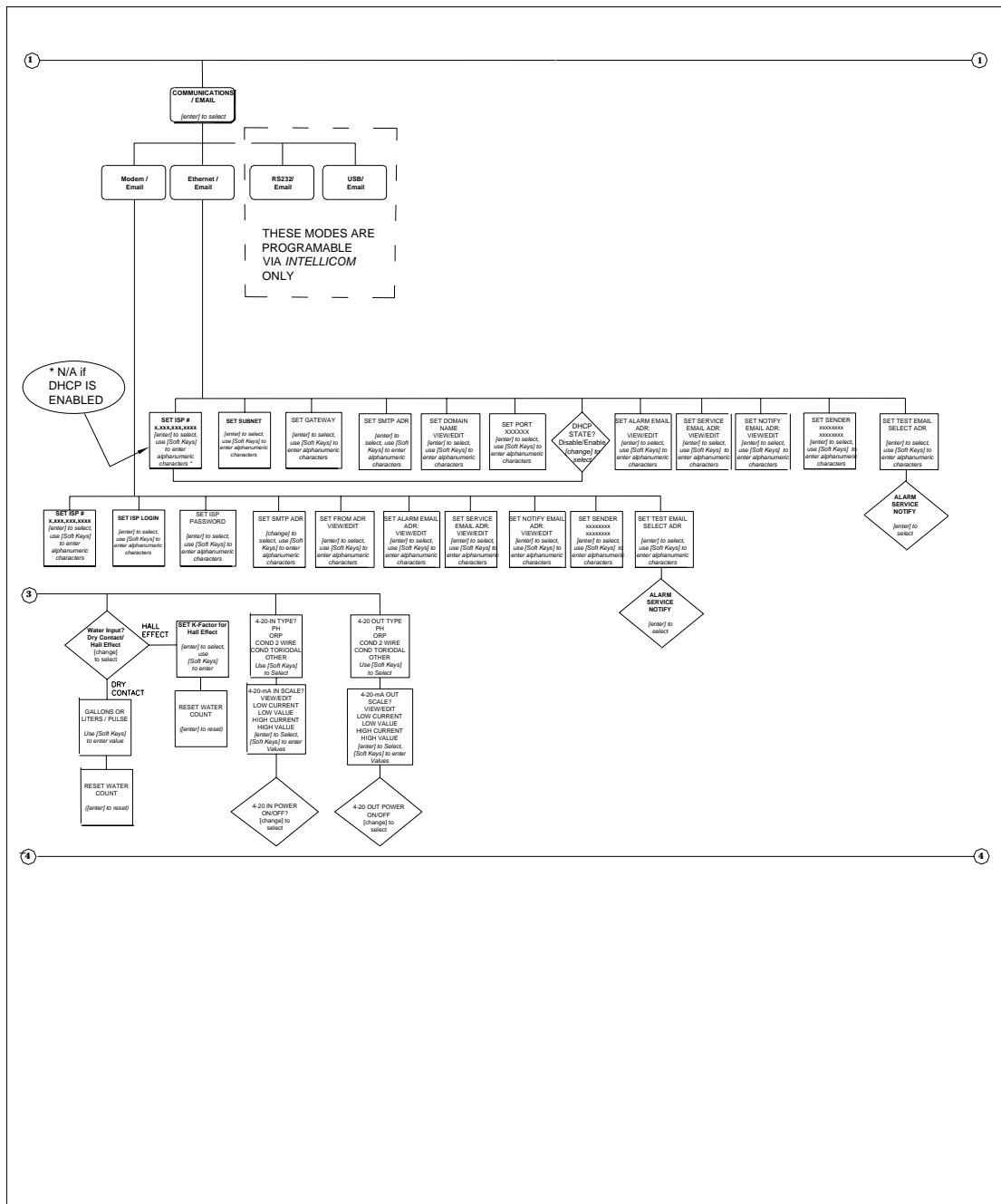

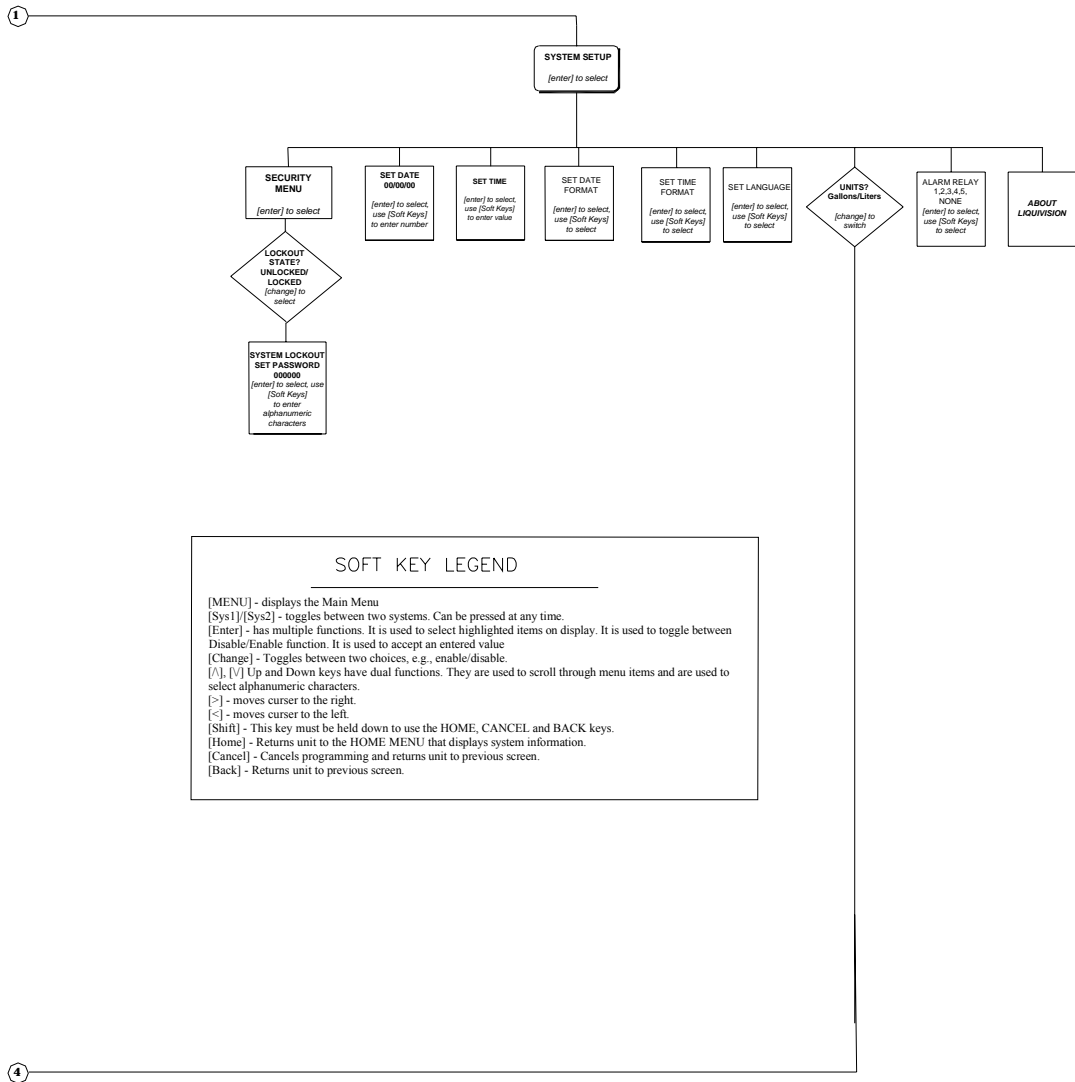

This page is blank.

Factory Service Policy

Your process control instrument is a state of the art microprocessor based unit. If you are experiencing a problem with your process control instrument, first consult the troubleshooting guide in this manual. If the problem is not covered or cannot be solved, contact Technical Services for assistance.

Trained technicians are available to diagnose your problem and arrange a solution. Solutions may include purchase of replacement parts or returning the unit to the factory for inspection and repair. All returns require a Return Authorization number to be issued by Pulsafeeder. Parts purchased to correct a warranty issue may be credited after an examination of original parts by Pulsafeeder. Warranty parts returned as defective which test good will be sent back freight collect. No credit will be issued on any replacement electronic parts.

Any modifications or out-of-warranty repairs will be subject to bench fees and costs associated with replacement parts.

Warranty

Pulsafeeder, Inc. warrants control systems of its manufacture to be free of defects in material or workmanship. Liability under this policy extends for 24 months from date of shipment. Electrodes/probes are considered maintenance items and as such are warranted for six (6) months from the date of shipment of the controller. Electrodes/probes purchased as spare parts are warranted for 90 days from date of shipment. The manufacturer's liability is limited to repair or replacement of any failed equipment or part, which is proven defective in material or workmanship upon completion of the manufacturer's examination. This warranty does not include removal or installation costs and in no event shall the manufacturer's liability exceed the selling price of such equipment or part.

The manufacturer disclaims all liability for damage to its products through improper installation, maintenance, use, or attempts to operate such products beyond their functional capacity, intentionally or otherwise, or any unauthorized repair. The manufacturer is not responsible for consequential or other damages, injuries, or expense incurred through the use of its products.

The above warranty is in lieu of any other warranty, whether expressed or implied. The manufacturer makes no warranty of fitness or merchantability. No agent of ours is authorized to provide any warranty other than the above.

FCC Warning

This equipment generates and uses radio frequency energy. If not installed and used properly, in strict accordance with the manufacturer's instructions, it may cause interference to radio communications. Operation of this equipment in a residential area is likely to cause interference in which case the user, at his own expense, will be required to take whatever measures necessary to correct the interference.

EC Declaration of Conformity

We, Pulsafeeder Inc., declare under sole responsibility that the Vision Series equipment to which this declaration relates is in sole conformity with relevant sections of the applicable EC standards and other normative documents listed on this document. If changes are made to the product which is covered by this declaration of conformity, the declaration of conformity is no longer valid.

- Application of EMC Directive (EN 64326:1997 includes amendment A1: 1998 and A2:2001)
- Application of LVD Directive (EN 61010-1:03/93 + A2:07/95 and/or IEC 61010-1:09/90 + A2:06/95)
- 2002/96/EG (WEEE) compliant

USA

Pulsafeeder, Inc.
27101 Airport Road
Punta Gorda, FL 33932
USA

European Union (EU)

Knight UK Limited
15 Brunel Centre
Newton Road
Crawley, West Sussex
RH10 9TU, UK